	प्लाज्मा भौतिकी केंद्र - प्लाज्मा अनुसंधान संस्थान	
	CENTRE OF PLASMA PHYSICS - INSTITUTE FOR PLASMA RESEARCH	
	नाजिराखात, सोनापुर-७८२ ४०२, असम, भारत	
	Nazirakhat, Sonapur-782 402, Assam, India.	
Tel. :- 0361 – 2220010	E-mail :- enquiry@cppiir.res.in	Web: www.cppiir.res.in
Fax :- 0361 – 2313110		

**MINOR FABRICATION WORKS
ENQUIRY**

ENQUIRY NO:CPP-IPR/MFW/2021-22/80

Date:18-11-2021

Due Date : 07-12-2021; 13:00 IST

Please send your offer in sealed envelope specifying Inquiry No, Date & Due Date, ALONG WITH your credentials for the following items:

Important Note:

Please note that e-mail quotations are not acceptable however you may send your queries (if any) to enquiry@cppiir.res.in

Please Ensure that your sealed quotation reaches this office not later than above mentioned due date and time.

Kindly go through the following document properly before Quoting attached here with.

1. Technical specification as enclosed.

2. Instruction to the bidders & terms and Condition (refer Form No:CPP-IPR-MFW-01-V1)

3. Bidding format (refer Bidding format MFW-Bid.)

GST for Goods and Services (IGST/CGST/SGST TAX BENEFITS): PLEASE REFER clause no:8 of Form No:CPP-IPR-MFW-01-V1

QUOTATION SHOULD BE ADDRESSED TO CHAIRMAN PURCHASE COMMITTEE ONLY.

Sr.No.	Description	Quantity	Unit
1	Fabrication and supply of Plasma chamber with Support Stand and Accessories (Detail list of items and drawings attached separately)	01 (One)	No.

Free Issue Material

Sr.No.	Description	Quantity	Unit	Value

Note: Please quote with complete technical details (Technical Compliance sheet and product data sheet)

Encl: As per attachment

Judip Kumar Barthak

Chairman, Purchase Committee

Specification/Tender Document for “Fabrication and supply of Plasma chamber with Support Stand and Accessories”

1. Introduction:

The tender for the “**Fabrication and supply of plasma chamber with support stand and accessories**” is mainly aimed for the fabrication of SS 304 plasma chamber with SS 304 knife edge electrodes as per the drawings provided by CPP-IPR. The plasma chamber will be used to produced atmospheric pressure plasma in Air or mixture of Oxygen/Nitrogen gas with different flow rate. This plasma chamber involves SS 304 Vacuum chamber, Top flange of the chamber made up of SS 304, bottom flange of chamber made up of Acrylic and mounting stand made up of mild steel. Top flange includes mounting of elbow shaped SS pipe as per the drawings provided by CPP-IPR. The chamber includes two side ports: one rectangular port with frame for holding toughen glass flange and another circular port with flange having 5 nos. of KF-25 port in which feedthrough will be used. There is an acrylic cylinder that stands on the bottom flange. Four numbers of knife edge SS electrodes are supported from bottom flange as per drawings.

A. Scope of Supply:

- i. SS Plasma chamber with support stand, top & bottom flanges, elbow, acrylic cylinder, rectangular glass flange, SS side flange with 5 nos. of KF-25 ports and four nos. of knife edge electrodes (all as per drawings).
- ii. All the flanges and ports should be covered including necessary bolts and washers, O-rings, Blank KF flanges, centre ring and clamp.
- iii. Complete assembled system should be supplied with 2 nos. of bellow and other additional/extra components as per requirements and the drawings.

2. Specifications/Drawings/List of Items

Sr No.	Particulars	Specification/Requirements	Quantity
1	Fabrication and supply of plasma chamber with support stand and accessories	Complete plasma chamber assembly with support stand, toughen glass flange, Acrylic cylinder, 'O' rings, fasteners, butter fly clamp for KF port, etc. (Design and dimensions are as per Sheet-1 & 13)	1 Set
Additional / Extra Items			
2	Acrylic bottom cover	As per drawing (Sheet-3 (part no. 1.3)	1 No.
3	Corrugated SS Bellow	Size-25 KF, Length: 1 meter	2 Nos.
4	Toughen Glass flange	As per drawing (Sheet-5 (part no. 1.8)	1 No.
5	Acrylic hollow cylinder	As per drawing (Sheet-13 (part no. 6)	2 Nos.
6	Additional set of 'O' rings	Complete set of "O" rings (extra) as per dimension in the drawing (Sheet-1-13)	2 Set
7	25 KF blank flange with centering ring assembly	As per standard	5 Set
8	Extra spacer and 'O' rings for feedthrough	As per drawing (Sheet-11 (part no. 4.3)	2 Set

Note:

1. Vendor will have to fill the table with the details and also accept the same.
2. Material for Chamber: **SS 304**
3. Support stand: **MS**
4. Surface finish should be as required for the vacuum compatibility
5. Tolerance: **± 0.1mm**
6. O-ring (neoprene) to be used should be in single-piece.

1. Special Terms and condition:

- i. Successful Fabricator/Vendor has to do design/drawing in detail for approval from CPP-IPR before commencing fabrication.

2. Delivery:

Within 1.5 months after the purchase order/work order date.

3. Inspection at vendor's site:

If required, CPP-IPR representative may perform pre-dispatch inspection for specifications/ dimensions and vacuum testing of the vacuum assembly. After fabrication vendor will have to intimate CPP-IPR regarding the fabrication status. A list of supply must be submitted by the vendor before dispatch/delivery.

Note: If CPP-IPR's representative will not visit the vendor's site for inspection, vendor must submit test report of the final fabricated components. Based on the review of the report, delivery of the components will be done to CPP-IPR.

4. Acceptance:

- i. Final acceptance will be given after the testing of fabricated Plasma Chamber with Support Stand and Accessories at CPP-IPR's site. Testing will be done as per the specifications.
- ii. Items should reach CPP-IPR with damage free condition.
- iii. Declaration from fabricator/vendor that the chamber should compatible for use under reduced pressure ($\sim 10^{-3}$ mbar)
- iv. Dimensional check on specification confirming compliance will be performed at CPP-IPR after delivery.

Compliance sheet for "Fabrication and supply of plasma chamber with support stand and accessories"

Note: Vendor will have to fill the table and also accept the same. This Compliance sheet has to be submitted along with the offer.

Sl. N.	Items	Description	Quantity	Vendor's Response
1	Fabrication and supply of plasma chamber with support stand and accessories	Complete plasma chamber assembly with support stand, toughen glass flange, Acrylic cylinder, 'O' rings, fasteners, butter fly clamp for KF port, etc. (Design and dimensions are as per Sheet-1 & 13)	1 Set	
Additional / Extra Items				
2	Acrylic bottom cover	As per drawing (Sheet-3 (part no. 1.3)	1 no.	
3	Corrugated SS Bellow	Size-25 KF, Length: 1 meter	2 no.	
4	Toughen Glass flange	As per drawing (Sheet-5 (part no. 1.8)	1 no.	
5	Acrylic hollow cylinder	As per drawing (Sheet-13 (part no. 6)	2 nos.	
6	Additional set of 'O' rings	Complete set of "O' rings (extra) as per dimension in the drawing (Sheet-1-13)	2 Set	
7	25 KF blank flange with centering ring assembly	As per standard	5 set	
8	Extra spacer and 'O' rings for feedthrough	As per drawing (Sheet-11 (part no. 4.3)	2 set	

Seal and Signature of the Vendor

Sheet: 1 (Complete Assembly)

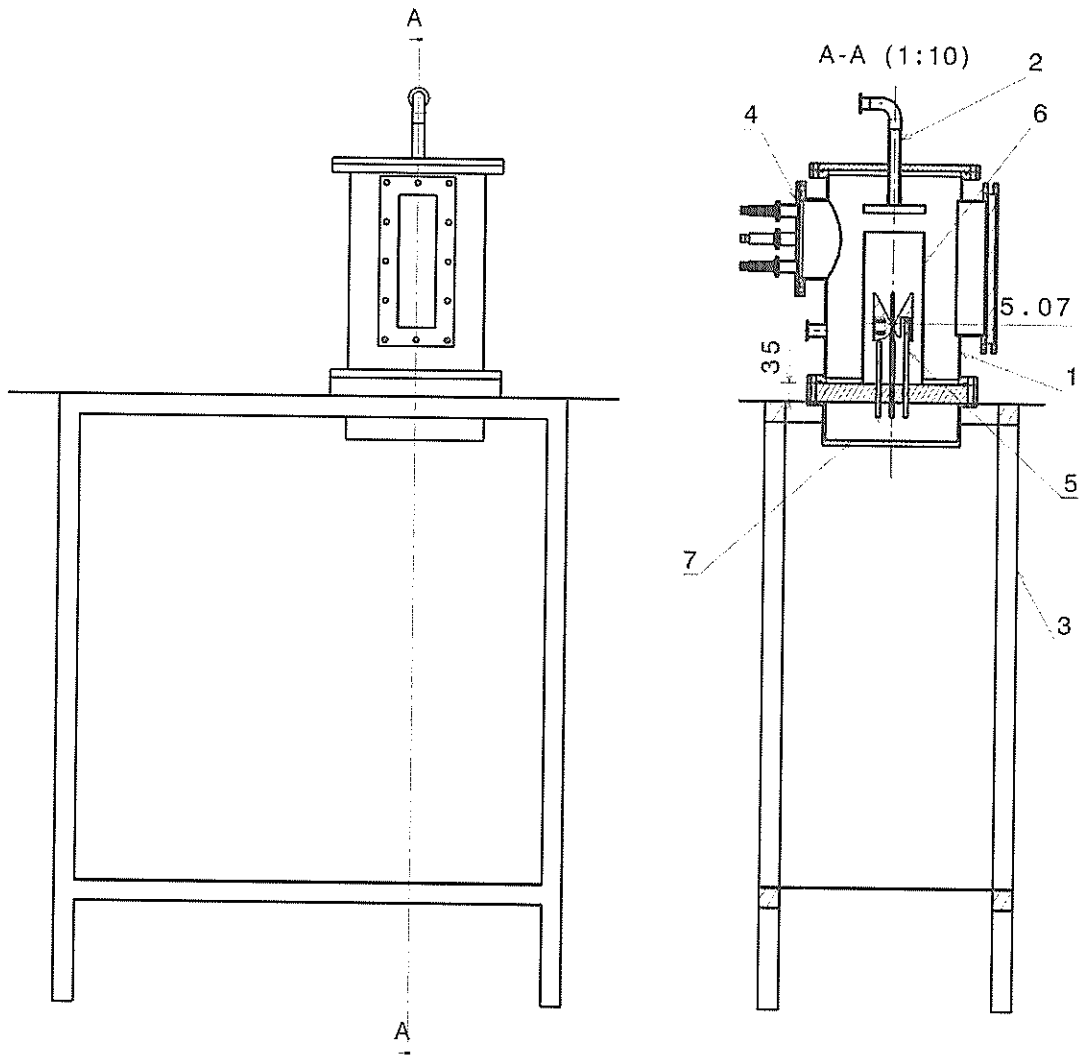

part no.	nomenclature	quantity	materials	remarks
1	chamber assy	1	As detail	
2	collector assy	1	SS304	
3	table assy	1	as detail	
4	F160 assy	1	as detail	
5	Electrode assy	1	SS304	
6	Acrylic hollow cylinder	1	acrylic	
7	Bottom cover	1	acrylic	

All dimensions in mm

DR. NO. - APD1

Sheet: 2 (Part No: 1)

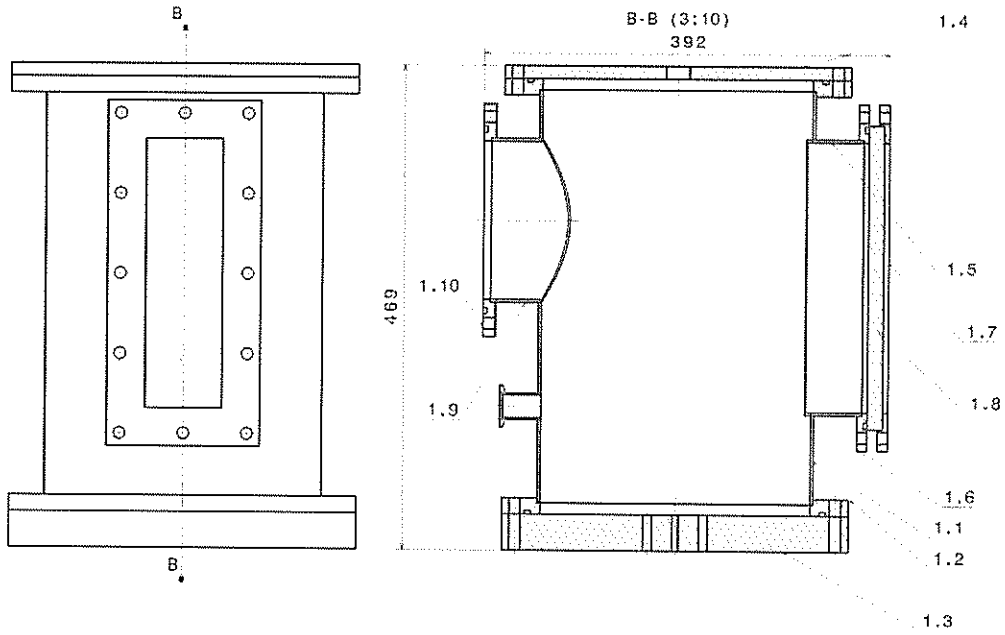

part no	nomenclature	material	quantity	remarks
1.1	chamber body	SS304	1	
1.2	Flange 1	SS304	2	
1.3	Flange 2	Acrylic	1	
1.4	Flange 3	SS304	1	
1.5	Neck 1	SS304	1	
1.6	Flange 4	SS304	1	
1.7	Flange 5	SS304	1	
1.8	view window	Glass	2	
1.9	Neck 2	SS304	1	
1.10	Flange 6	SS304	1	

1

All Dimensions are in mm

DR. NO. - APD2

Sheet: 3 (Part No: 1)

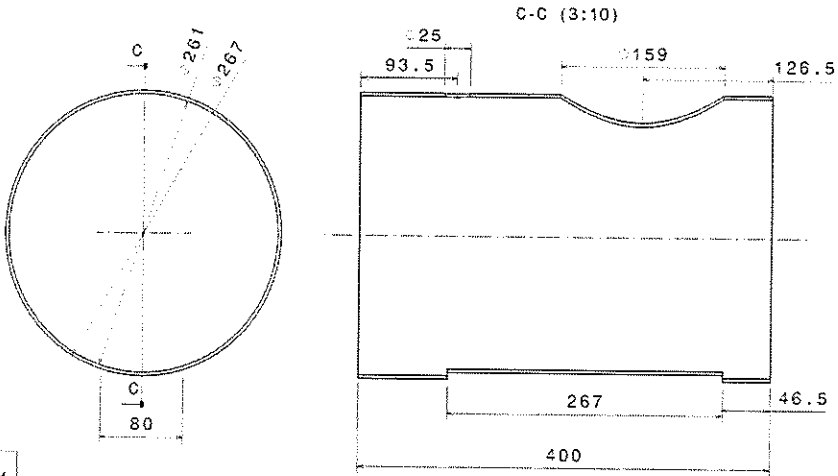

1.1

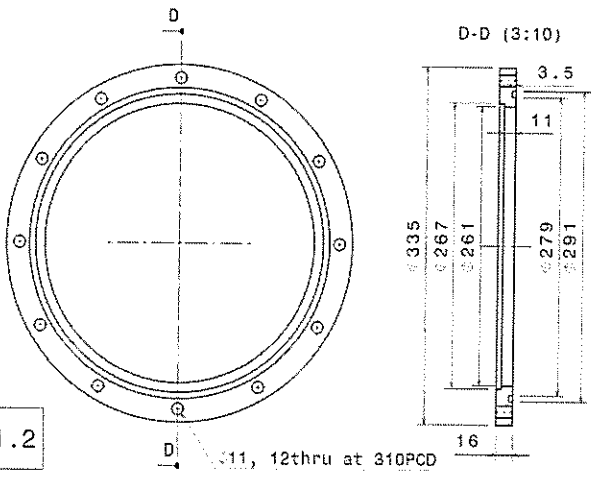

1.2

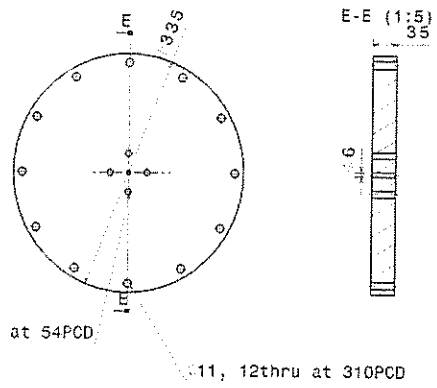

1.3

All Dimensions in mm
DR. NO. - APD3

Sheet: 4 (Part No: 1)

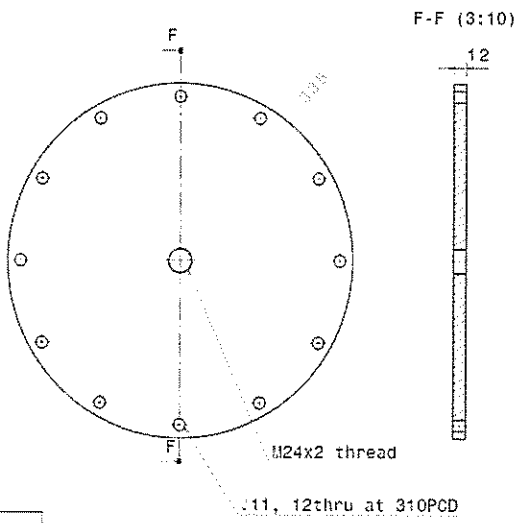

1.4

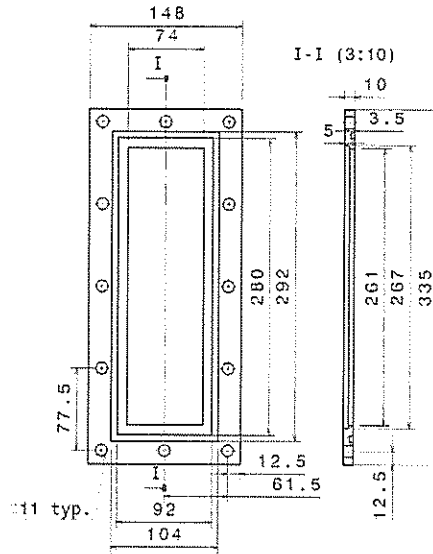

1.6

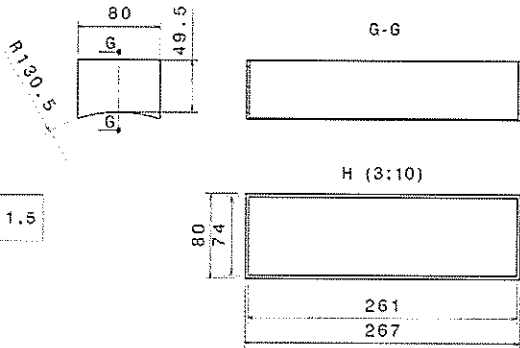

1.5

All Dimensions in mm

DR. NO. - APD4

Sheet: 5 (Part No: 1)

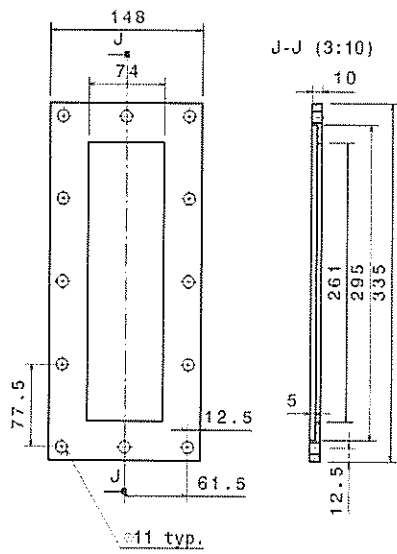

1.7

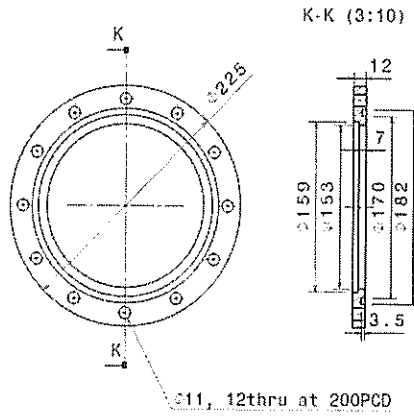

1.10

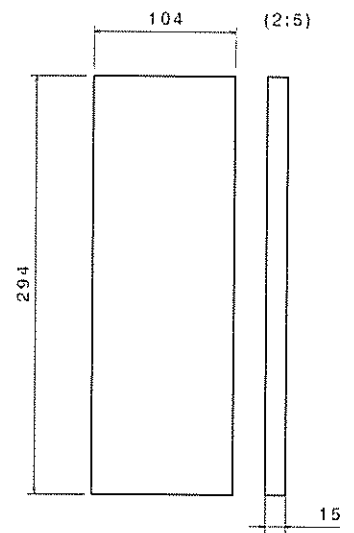

1.8

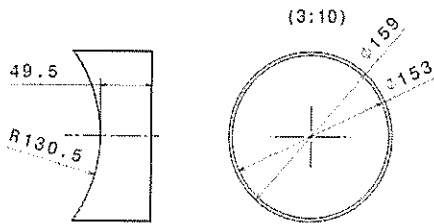

1.9

All Dimensions in mm

DR. NO. - APD5

Sheet: 6 (Part No: 2)

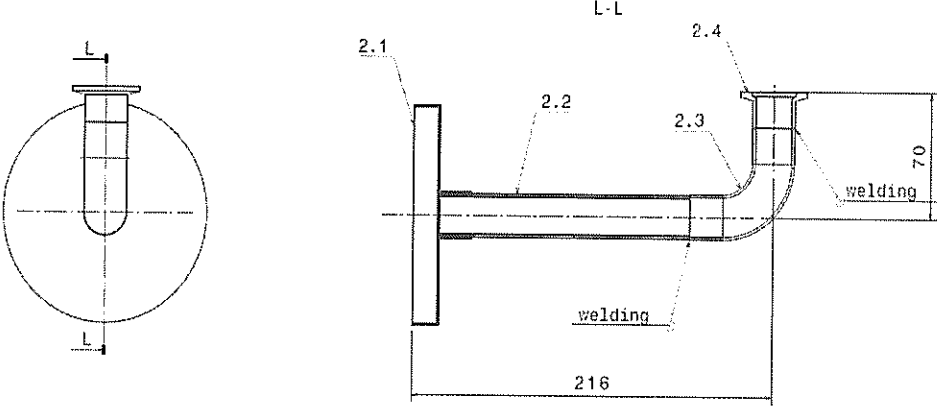

part no	nomenclature	material	quantity	remarks
2.1	cap	SS304	1	
2.2	pipe	SS304	1	
2.3	Bend	SS304	1	
2.4	25KF	SS304	1	

All Dimensions in mm

DR. NO. - APD6

Sheet: 7 (Part No: 2)

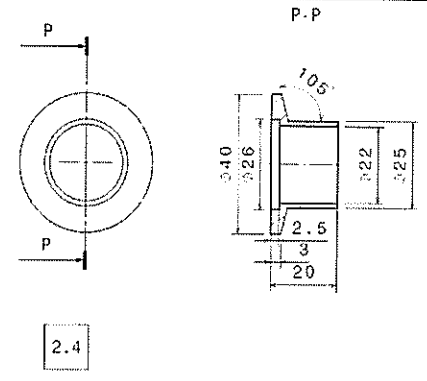
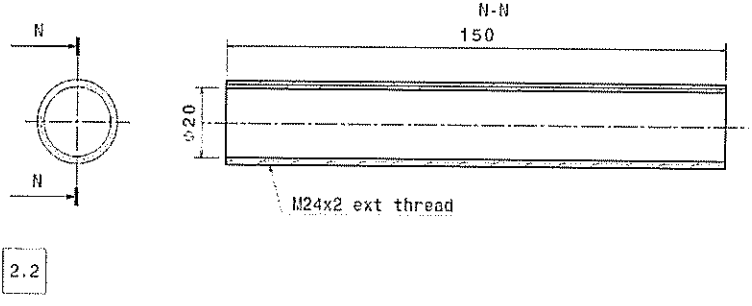
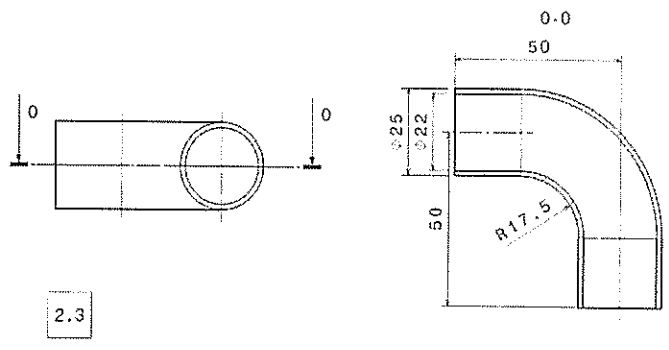
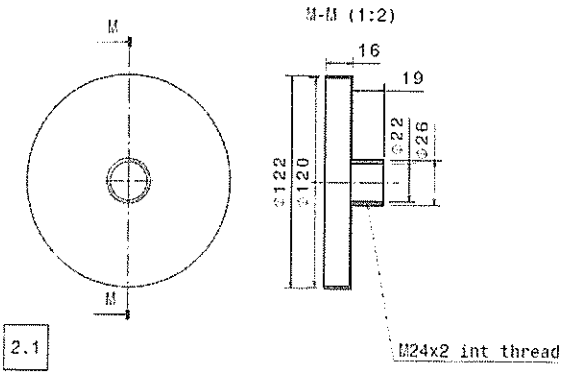

ALL Dimensions in mm
DR. NO. - APD7

Sheet: 8 (Part No: 3)

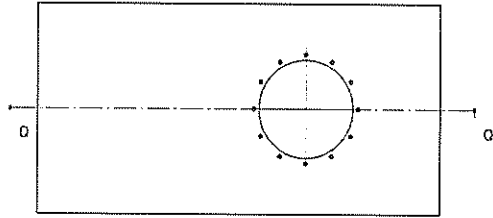

part no	nomenclature	material	quantity	remarks
3.1	top plate	SS304	1	
3.2	frame	MS	1	
3.3	bottom plate	SS304	1	

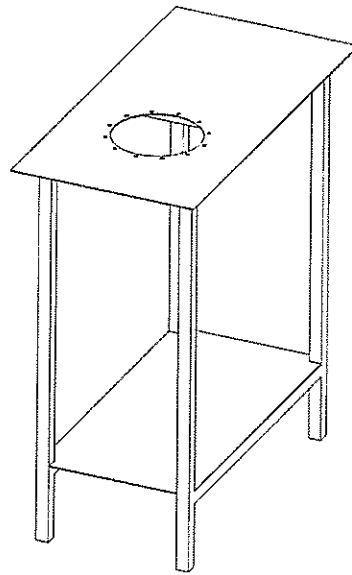
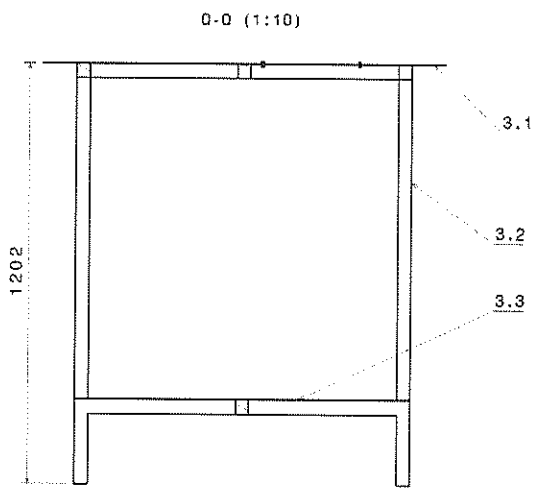

All Dimensions in mm

DR. NO. - APD8

Sheet: 9 (Part No: 3)

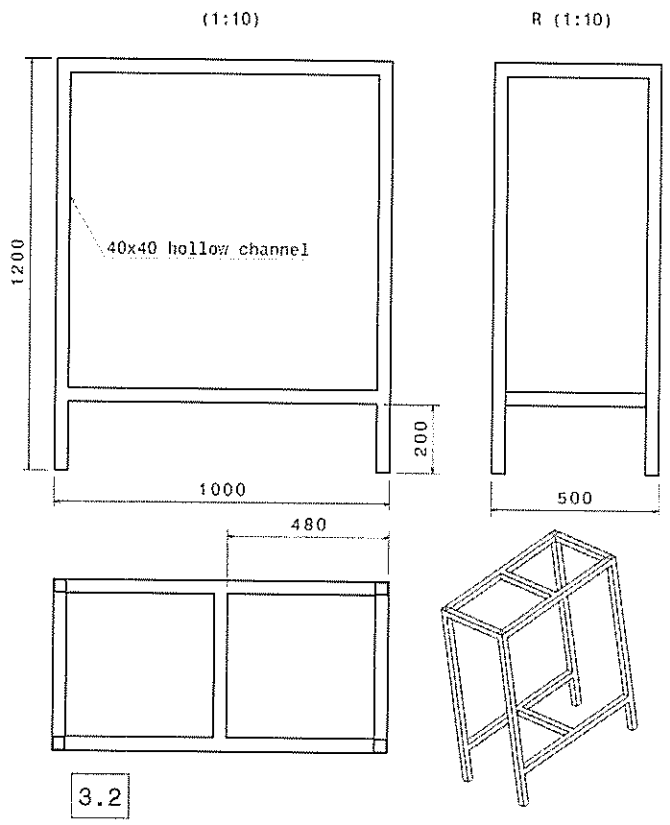
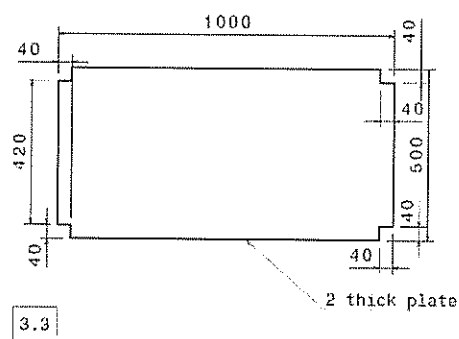
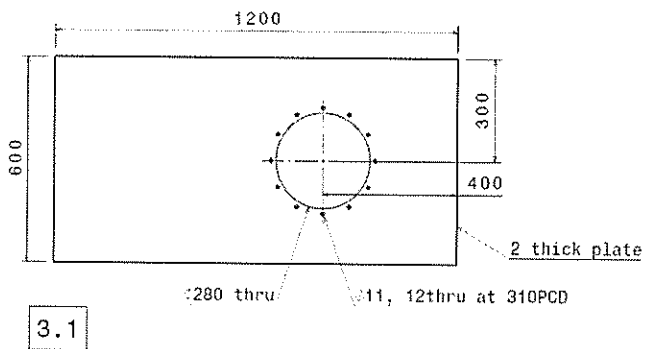

All Dimensions in mm
 DR. NO. - APD9

Sheet: 10 (Part No: 4)

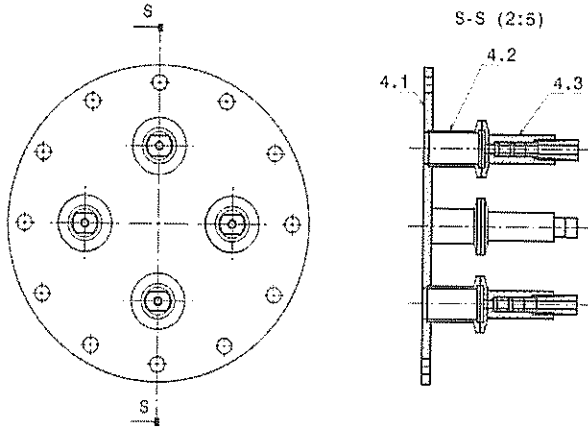

part no.	nomenclature	quantity	material	remarks
4.1	F160 Flange	1	SS304	
4.2	25KF neck	4	SS304	
4.3	Wilson feedthrough	4	SS304	For inserting tube dia of 5mm

All Dimensions in mm

DR. NO. - APD10

Sheet: 11 (Part No: 4)

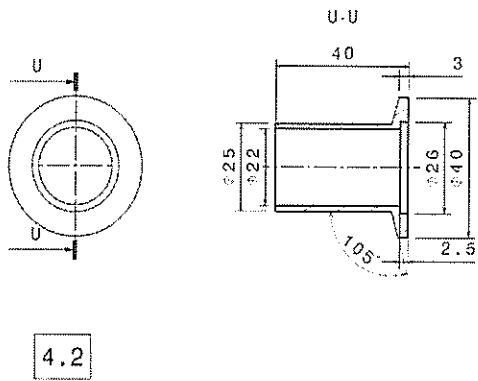
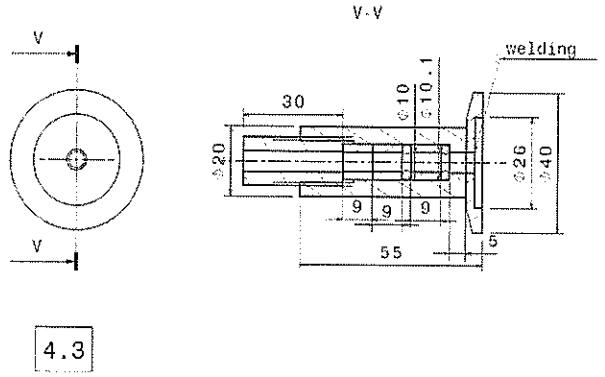
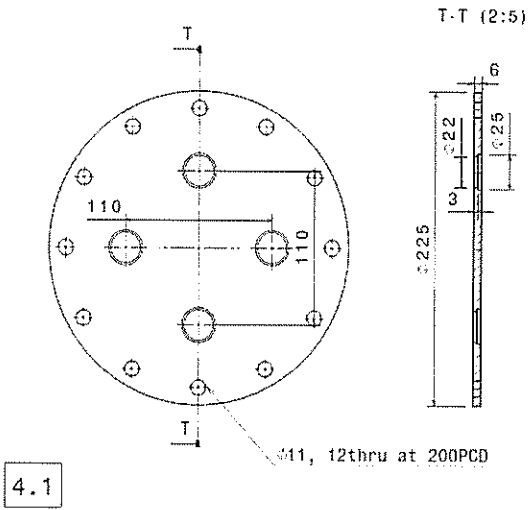

All Dimensions in mm

DR. NO. - APD11

Sheet: 12 (Part No: 5)

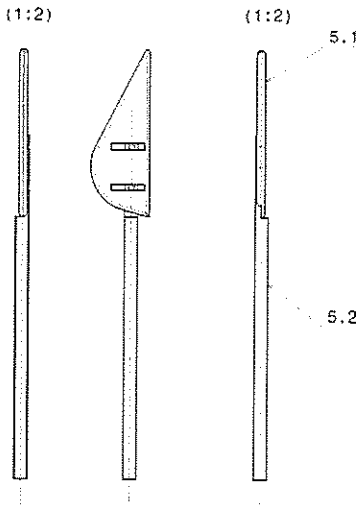

5

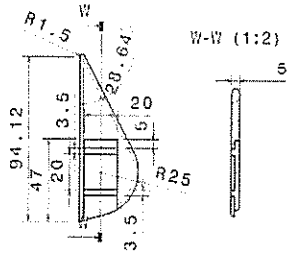

5.1

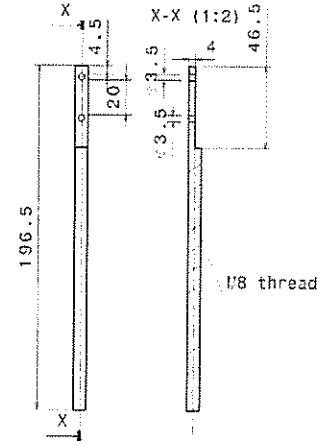

5.2

(1:2)

All Dimensions in mm

DR. NO. - APD12

part no	nomenclature	quantity	material	remarks
5.1	Electrode plate	4	SS304	
5.2	Electrode rod	4	SS304	

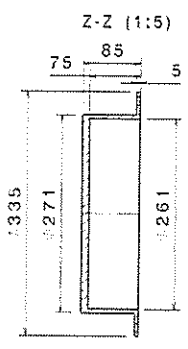
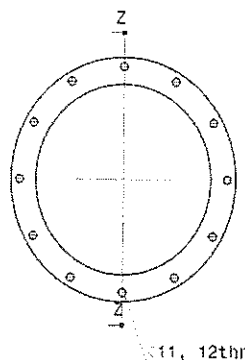
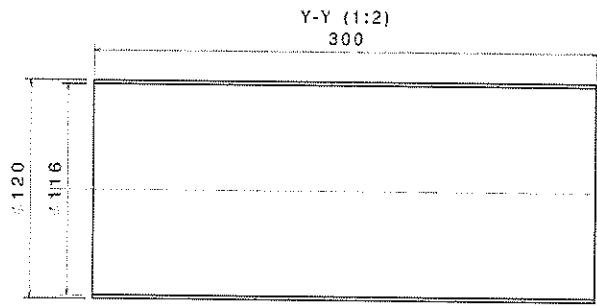
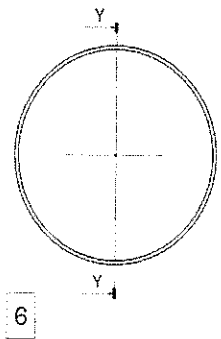

11, 12thru at 310PCD

All Dimensions in mm
DR. NO. - APD13

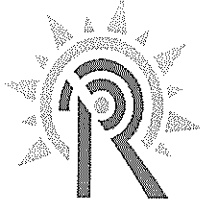
	प्लाज्मा भौतिकी केंद्र - प्लाज्मा अनुसंधान संस्थान	
	CENTRE OF PLASMA PHYSICS - INSTITUTE FOR PLASMA RESEARCH	
	नाजिराखात, सोनापुर-७८२ ४०२, असम, भारत Nazirakhat, Sonapur-782 402, Assam, India.	
	Tel. :- 0361 – 2220010 Fax :- 0361 – 2313110	E-mail :- enquiry@cppipr.res.in Web: www.cppipr.res.in

Form No: CPP-IPR-MFW-01.V1

INSTRUCTIONS TO BIDDERS AND TERMS AND CONDITIONS

1. The Quotation and any order resulting from this enquiry shall be governed by our Conditions of Work Order and Contractor quoting this enquiry shall be deemed to have read and understood the same completely.
2. Where counter terms and conditions have been offered by the Tenderer, the same shall not be deemed to have been accepted by CPP-IPR unless our specific written acceptance thereof is obtained.
3. **Quotation:** Quotation should be submitted in the prescribed QUOTATION FORMAT attached with this Enquiry and the same should be submitted in a sealed envelope super-scribing the same with our enquiry No., date, due date and brief description of item on or before the due date. Late/delayed/incomplete/unsigned quotations will not be considered. Envelopes received without Enquiry number, date, due date and brief description of item may be rejected. The quoted prices should be firm for a period of 90 days from due date for placing order. CPP-IPR is not bound to accept lowest rate/s. CPP-IPR reserves the right to place on one or more parties. The scope of supply includes insurance by the Contractor.
4. **Specifications:** Goods should be offered strictly confirming to our specifications/drawings. Deviation, if any, should be clearly indicated by the contractor in their quotation. The Tenderer should also indicate the Make/Type number of the goods offered and catalogues, technical literature and samples, wherever necessary should accompany the quotation. Clarification/s on drawings should be obtained before submitting quotation.
5. **Terms of Prices:** Quotation should be submitted on door delivery basis without extra charge wherever possible. For quotations on Ex-Works, Ex-godown basis the approximate packing and forwarding charges should be indicated by the contractor. In the case of local contractors, the goods are to be delivered at our stores free of charge.
 - 5.1 In respect of tenders on Ex-works basis, in case the tenderer has not mentioned in the offer packing, forwarding and transportation charges for safe delivery up to Purchaser's site, 2% of the price quoted towards packing (in respect of both local and outstation firms), 1% of the basic price quoted towards safe delivery charges in respect of local tenderer and 3% of the basic price quoted towards safe delivery charges in respect of outstation firm will be added for comparison of offers on safe door delivery at Purchaser's site
 - 5.2 Prices are required to be quoted according to the units indicated in the tender form/Enquiry. When Quotations are given in terms of units other than those specified in the tender form, relationship between the two sets of units must be furnished.
6. Tender should be free from Correction and Erasures. Corrections, if any, must be attested. All amounts shall be indicated both in words as well as in figures. Where there is difference between amounts quoted in words and figures, amount quoted in words shall prevail. Unsigned quotations will summarily be rejected. If there is a discrepancy between the unit price and total price, unit price shall prevail.

7. CPP-IPR shall be under no obligation to accept the lowest or any tender and reserves the right of acceptance of the whole or any part of the tender or portion of the quantity offered and the tenderers shall supply the same at the rate quoted.

8. **Goods & Services Tax (GST):** The details of Taxes/GST and other levies legally applicable and intended to be claimed should be clearly indicated in the tender. Where this is not done, no claim on these accounts would be admissible later.

a) GST for Goods (IGST/CGST/SGST TAX BENEFITS):

CPP-IPR is entitled to avail tax benefit as per the following notifications issued by Ministry of Finance, Department of Revenue, Government of India:

(1) No: 47/2017-INTEGRATED TAX (RATE) DATED 14/11/17 for IGST

(2) No: 45/2017-CENTRAL TAX (RATE) DATED 14/11/17 for CGST

And,

CPP-IPR is entitled to avail tax benefit as per the following notifications issued by Finance (Taxation) Department, Government of Assam:

(1) Notification No. 45/2017 DATED 14/12/17 for SGST

As per above notifications CPP-IPR will bear only 5% IGST for procurement of goods from outside Assam & 2.5% CGST and 2.5% SGST (total 5%) for procurement of goods within Assam. Vendors are required to charge tax as per these notifications while quoting/supplying the goods. Deviations, (if any) should be clearly mentioned in the quotation/offer.

Please specify the HSN codes while quoting.

b) GST for Services:

As applicable. Specify the SAC codes wherever services are involved.

9. **Delivery Date:** Delivery period is essence of the Contract. Contractor must indicate the firm delivery date by which the goods will be dispatched or delivered by them from the date of our order. Delivery period shall be clearly indicated against each item separately.

10. **Price/ Purchase Preference:** Purchase/Price preference to industries will be given as per the policy of the Government of India in force at the time of evaluation provided their offer is in compliance with the conditions of the policy.

11. **Liquidated Damages:** The successful Vendor/Bidder should pay liquidated damages @ ½% (half percent) of the total work order value for the delay of each week in the scheduled date of completion of the work envisaged in the Work Order subject to a maximum of 5% (Five percent) of the total Work Order value.

12. **Inspection:** Goods on its arrival at CPP-IPR will be inspected by Stores, and his decision in the matter will be final. However, where the items are required to be inspected at the Contractors Premises, Contractor has to give advance notice regarding readiness of the Goods to enable us to depute our representative for inspection.

13. **Payment:** Payment will be arranged for accepted goods only within 30 days from the date of receipt of goods at CPP-IPR and bills in our accounts section, completed in all respects.

14. No correspondence will be entertained within 30 days from the date of receipt of good and bills, whichever is later.
15. The Contractor shall at all times indemnify the purchase against all claims which may be made in respect of the stores for infringement of any right protected by Patent Registration of design or Trade Mark and shall take all risk of accidents or damage, which may cause failure of supply from whatever cause arising and the entire responsibility for sufficiency of all means used by him for the fulfilment of the contract.
16. The Acting Centre Director, CPP-IPR reserves the right to accept or reject any quotations fully or partly or to cancel the enquiry without assigning any reason.
17. **Jurisdiction:** The contract shall be governed by the Laws of India for the time being in force. The Courts of Guwahati only shall have jurisdiction to deal with and decide any legal or dispute arising out of this Contract.

Judij Kumar Barbata

Chairman, purchase Committee

(This need to be printed in Bidders letter head)

1. Please quote with complete technical details along with technical compliance sheet.
2. Quotation should be submitted in the format given below, else IPR shall not consider the offer by the vendor.

NAME OF PARTY : _____
 ENQUIRY NO: _____
 QUOTATION No. & DATE : _____

Currency of Quotation: Indian Rupees

Sr. No.	Item Description	HSN/SAC Code	Quantity	Unit Rate (Basic)	Packaging & forwarding (P&F)	Applicable GST	Rate (incl P&F and GST)	Total Value
			a	b	c	d	e = b + c + d	f = a * e
1								
2								
3								
4								
5								
6								

Sr. No.	Particular	Remarks
I.	Ex-works / FOR Destination	
II.	Freight	
III.	Insurance	
IV.	Delivery Period	
V.	Payment (CPP-IPR terms will apply)	
VI.	Guarantee / Warrantee	
VII.	Validity Period	
VIII.	Discount (if any)	
IX.	Remarks	

Place: Authority Signatory

Date: Company Seal

Note:

1. Bidder should submit the copy of GSTIN / ARN Certificate along with the offer.
2. Bidder should specify the SUPPLY and SERVICE rates/ charges separately wherever applicable.