

This file has been cleaned of potential threats.

To view the reconstructed contents, please SCROLL DOWN to next page.

CENTRE OF PLASMA PHYSICS INSTITUTE FOR PLASMA RESEARCH
NAZIRAKHAT, SONAPUR-782402, KAMRUP (M), ASSAM, INDIA

Phone: +91-361 2220010/2313116

Fax: +91-361 2313110

TENDER NOTICE NO. CPP-IPR/TPT/TN/PUR/2018-19/ 29

DATED 02/08/2018

Sealed tenders are invited in TWO PARTS from the eligible vendors for the following item.

Sr. No	Tender Notice No.	Item description	Qty	Due Date & Time for		Tender Fee	Earnest Money Deposit (EMD)
				Submission of Tender	Opening of Tender		
01	CPP-IPR/TPT/TN/PUR/2018 - 19/29 DATED 02/08/2018 (TWO PART TENDER)	Supply of Fibre Optics Links Module [Transmitter and Receiver (TX & RX)] for Negative Hydrogen Ion Extraction facility at CPP-IPR (As per floating signals mentioned in the signal list)	For 51 Nos of floating channels as per the signal list	25/09/2018 By 1300 Hrs. I.S.T	25/09/2018 By 1530 Hrs. I.S.T	₹ 300.00 or equivalent foreign currency	₹ 49,000.00 or equivalent foreign currency

1. For further details, please visit CPP-IPR Website: <http://www.cppipr.res.in>

2. Interested parties may download the tender documents & submit their quotation, if they fulfil the eligibility criteria.

3. Tender documents will also be issued from this office up to 10/09/2018
Interested parties may approach us with tender fee.

**CENTRE OF PLASMA PHYSICS
INSTITUTE FOR PLASMA RESEARCH
NAZIRAKHAT, SONAPUR -782402, KAMRUP (M)
ASSAM, INDIA
Tele No. +91-361 2220010/2313116
Fax No. +91-361-2313110
E-mail: enquiry@cppipr.res.in**

TWO-PART TENDER

Tender No. CPP-IPR/TPT/TN/PUR/2018-19/29

Date: 02.08.2018

BID DUE DATE 25/09/2018 @ 1300 Hrs IST

Date of Opening 25/09/2018 @ 1530 Hrs IST

M/s _____

Sub: Supply of Fibre Optics Links Module [Transmitter and Receiver (TX & RX)] for Negative Hydrogen Ion Extraction facility at CPP-IPR.

Dear Sirs/Madams,

This document contains Invitation to tender, tendering conditions, contracting conditions and specifications of stores required by us. The tenders in respect of this case are to be submitted in **TWO-PARTS**. If you are interested to quote, please go through the contents particularly the tendering conditions and ensure that your quotation reaches us on or before the due date indicated above.

Yours faithfully,

**Chairman
Purchase Committee
CPP-IPR**

CENTRE OF PLASMA PHYSICS
INSTITUTE FOR PLASMA RESEARCH
(An Autonomous Institute under Department of Atomic Energy, Govt. of India)
NAZIRAKHAT, TEPESIA, SONAPUR -782 402, ASSAM, INDIA
Phone: +91-361 2220010/23131116, Fax: +91-361 2313110
Email: enquiry@cppipr.res.in

Instructions to Tenderers indicating the Tender Number, Last Date and Time for Receipt of Tender, place at which the Tender can be submitted and the Date/Time and Venue in which Tenders will be opened.

Tender No. CPP-IPR/TPT/TN/PUR/2017-18/29 dated 02/08/2018

I	Last Date for reaching both Part - I (Technical & Commercial) and Part-II (Price) of the Tender in Sealed envelopes to Centre of Plasma Physics - Institute for Plasma Research to reach on or before the last date & time.	1300 Hours (IST) on 25/09/2018
II	Due Date and Time for Opening of Part-I of the Tender i.e. Techno Commercial Part	25/09/2018 1530 Hours (IST) on
III	Venue for Opening the Tender	CENTRE OF PLASMA PHYSICS INSTITUTE FOR PLASMA RESEARCH NAZIRAKHAT, SONAPUR - 782402 KAMRUP (M), ASSAM, INDIA

CENTRE OF PLASMA PHYSICS
INSTITUTE FOR PLASMA RESEARCH
(An Autonomous Institute under Department of Atomic Energy, Govt. of India)
NAZIRAKHAT, TEPEZIA, SONAPUR -782 402, ASSAM, INDIA
Phone: +91-361 2220010/23131116, Fax: +91-361 2313110
Email: enquiry@cppipr.res.in

INSTRUCTION SHEET

TENDER NOTICE No. CPP-IPR/TPT/TN/PUR/2018-19/29 dated 02/08/2018

Supply of Fibre Optics Links Module [Transmitter and Receiver (TX & RX)] for Negative Hydrogen Ion Extraction facility at CPP-IPR

1. This is a TWO PART Tender. Bidder should submit the bid in Two Parts,

(i) PART – I : Technical Bid & Commercial Terms and Conditions Except price.

(ii) PART – II : Price Bid (Price Alone)

Bidders shall submit the bid in duplicate.

2. PRICE BID FORMAT: Bidder shall quote price on the Price Bid Format given in Section-E of tender documents.

3. Full details and specifications of the items and general instructions to be followed regarding submission of tenders are indicated in the tender documents.

4. Proof for fulfilment of eligibility criteria mentioned above should be submitted along with the tender. If the tender is submitted without valid documents, Purchaser shall not consider your offer. Tenders received without proof of eligibility criteria will be rejected.

5. While requesting for Tender Documents, such request shall indicate the "REQUEST FOR TENDER DOCUMENTS AGAINST TENDER NOTICE NO. CPP-IPR/TPT/TN/PUR/2018-19/29 Dated 02/08/2018"

6. Tender Fee: The tender fee (non-refundable) of Rs. 300.00 (Rupees Three Hundred only) or equivalent foreign currency should be made in the form of DEMAND DRAFT drawn in favour of *Institute for Plasma Research A/C CPP* and payable at *Sonapur, Assam*. Vendor's name and tender number shall be indicated on the reverse side of the Demand Draft.

7. DD should not be prior dated to the date of advertisement. Separate request letter and separate Demand Draft shall be sent for each tender.

8. Those who use the downloaded tender documents from CPPIPR Website may submit the prescribed Tender Fee keeping in a separate envelope along with the tender. This envelope should be marked as "TENDER FEE".

9. No request for the extension of due date will be considered.

10. Late/Delayed offers will not be accepted.

11. Due date for submission of Tender: Tender in a sealed envelope (Part-I, Technical Bid, Commercial Terms & Conditions and Tender Fee & EMD in one envelope and Part-II Price-Bid in another envelope) super scribing the envelope with the above tender no., date, due date and brief description of tendered item should be submitted by 1300 hrs. I.S.T. 25/09/2018 to the Centre Director, at the following address

**Centre Director,
Centre of Plasma Physics
Institute for Plasma Research
Nazirakhat, Sonapur – 782402.
Assam, INDIA.**

Part-I (Techno-Commercial Bid: - Except Price) will be opened on the same day at 1530 Hrs. I. S. T. in the presence of attending tenderers.

Part-II (Price Bid): Date of opening of Price Bid of eligible Bidder/s will be intimated to them later on.

12. In the event of any date indicated above is declared as a Holiday, the next working day shall become operative for the respective purpose mentioned herein.

13. CPP-IPR will not be responsible for any delay/loss of Tender or documents in transit.

14. Bidders should furnish/enclose full technical details/literature, delivery period and confirm the terms and conditions attached with the tender.

15. Bids received without the prescribed Tender Fee and EMD will be rejected.

16. Bidder will submit technical bid, commercial bid and all supporting documents pertaining to this tender in English.

17. Technical Specifications: As per SECTION-B

18. Rejection of bid: Noncompliance of tender specifications and/or tender documents including terms and conditions will lead to rejection of quotations received.

19. All communications related to this tender must be sent to,

**Centre Director,
Centre of Plasma Physics
Institute for Plasma Research
Nazirakhat, Sonapur-782402
Kamrup (M), Assam, INDIA.
Phone : 0361 2220010/2313116
Fax : 0361-2313110
e-mail : enquiry@cppipr.res.in**

20. The Centre Director, CPPIPR reserves the right to accept or reject any offer in full or part thereof without assigning any reason thereof.

ELIGIBILITY CRITERIA

(The bidder is required to submit all supporting documents as proof for the compliance of the following criteria. The attachments must be serially labelled with the number as given in the table below. Bids received without valid documents and/or incomplete and irrelevant documents are likely to be rejected summarily)

Sr. No.	Essential Eligibility compliance	Evidence for submission	Attachment Sr. No. of proofs and evidence
1	Bidder should be a manufacturer Or an authorized distributor of Fibre Optics Links Module [Transmitter and Receiver (TX & RX)] with authorization letter.	The vendor should submit company profile and organization structure in details.	
2	Technical Competence and relevant Experience as on the date of tender notice: - Bidder should have successfully developed and delivered at least one unit of Fibre Optics Links Module [Transmitter and Receiver (TX & RX) modules within last five (5) years from the date of tender notice.	Bidder should submit unpriced purchase order with work completion certificate or any other relevant documents confirming the eligibility compliance as a proof of evidence.	
3	Financial Capacity :- Bidder should have average annual turnover during last 3 consecutive financial years starting from Financial Year 2014-2015 of at least INR 61,00,000/- or equivalent foreign currency.	Audited balance sheets for the last 3 financial years (2015-2016, 2016-2017 and 2017 - 2018) to be submitted.	
4	Single Order Value: - Bidder should have executed single order having value of minimum INR 19,60,000/- or equivalent foreign currency in the field of Fibre Optics Links Module [Transmitter and Receiver (TX & RX) modules	Bidder should submit the copies of purchase orders (priced) with completion/installation certificate.	
5	Quality Management :- Bidder should have valid standard quality management certification (s) such as ISO 9001:2008 certification	Bidder should submit valid ISO 9001:2008 certificate or its equivalent.	

NOTE:

- (1) If, Indian Agent submits offer on behalf of their overseas principal/OEM, all documents pertaining to eligibility criteria should be attached of their principal/OEM ONLY.
- (2) Original documents shall be produced for verifications, if required.
- (3) If quotation is submitted without attaching the documents in support of the eligibility criteria, will summarily be rejected without further communication.
- (4) The bidder shall not be under declaration of ineligibility for corrupt or fraudulent practices or blacklisted with any of the Government agencies.

NOTE: Issue of tender documents does not mean that a vendor is qualified to submit tenders. IPR's decision to consider as to whether a vendor has met with the eligibility criteria is final.

TWO-PART TENDER

SECTION – A

Invitation to Tender and Tendering Conditions

1.0 INVITATION TO TENDER

- 1.1 Centre of Plasma Physics-Institute for Plasma Research (CPP-IPR) invites sealed tenders in DUPLICATE for supply of Plant, Machinery, Equipment/ Components to the specifications detailed in Section "C" to this tender document. The conditions of contract/purchase order which will govern the contract pursuant to the tender are as contained in Section "B" of this tender document. If you are in a position to quote for supply in accordance with the technical specifications indicated in Section "C" to this tender document and as per the conditions stipulated in this Section and Section B, please submit your offer in a manner and method specified below.

2.0 MANNER AND METHOD FOR SUBMISSION OF TENDERS

- 2.1 All tenderers in response to this invitation shall be submitted in Two Parts as under and in the different envelopes.

- 2.1.1 **Part-I (Techno-commercial):** This part of the tender shall include/contain documents related to eligibility criteria, all technical details, technical specifications, drawings and also the commercial terms and conditions of contract for the supplies to be made and the services to be rendered **EXCLUDING ANY PRICE DETAILS THEREOF.**

Proof for fulfilment of eligibility criteria mentioned in Annexure-A should be submitted along with the tender. If the tender is submitted without valid documents, we shall not consider your offer. Tenders received without proof of eligibility criteria will be rejected.

- 2.1.2 **Part-II (Price):** This part should contain only the prices of the stores offered for the services to be rendered. Part-II (Price) should be furnished in accordance with the format provided by the Purchaser at Section "D" of this tender document
- 2.1.3 If tenderer includes prices of any nature in Part-I (Techno-commercial) of the tender such offers are liable for rejection without any notice to the tenderers.

3.0 EARNEST MONEY DEPOSIT (EMD)

- 3.1 The Tenderer shall submit, as part of its bid, interest free Earnest Money Deposit (EMD) for an amount as specified in the Tender Notice. In the case of foreign bidders, the EMD shall be submitted either by the principal or by the Indian agent and in the case of indigenous bidders; the EMD shall be submitted by the manufacturer or their specifically authorized dealer/bidder. EMD shall be submitted by way of Demand Draft from **SBI/nationalized banks or any one of the scheduled banks mentioned in the bracket (Axis Bank, HDFC Bank, ICICI Bank and IDBI Bank)** issued in favour of **"Institute for Plasma Research A/C CPP"** and payable at **Sonapur-782402. Tender received without EMD will be rejected at the discretion of CPP-IPR.**
- 3.2 The EMD of unsuccessful Tenderer will be discharged/returned after finalizing award of the Contract/placement of Purchase order.
- 3.3 The successful Tenderers EMD shall be discharged upon the Bidder submitting the Security Deposit as specified in the contract/purchase order, without any interest.

3.4 **Exemption from payment of EMD:** The firms registered with DGS&D, NSIC, DPS or Micro & Small Enterprises (MSEs) which are actual producers/manufacturers of tendered items are exempted from payment of EMD provided valid registration certificate is to be submitted along with the offer. In the case of foreign bidders, payment of EMD is exempted if they submit their bid directly or through their Indian agent in **foreign currency** against the tender document bought by them, so that the order can be placed directly on their Principals.

3.5 **The EMD may be forfeited:**

3.5.1 If a Tenderer withdraws or amends or modifies or impairs or derogates its bid during the period of bid validity specified by the Bidder on the Bid Form;

or

3.5.2 In case of a successful tenderer, if the tenderer fails to furnish order acceptance within 15 days of the order or fails to submit the Security Deposit within 21 days from the date of contract/order.

4.0 LATE/DELAYED TENDERS

4.1 If the envelope containing Part-I (Techno-commercial) and Part-II (Price) does not reach the Centre Director, CPP-IPR on or before the due date and time specified for its receipt, such tenders will be treated as Delayed/Late tenders and will neither be opened nor considered by the Purchaser and will be summarily rejected. The tenderers should therefore take care and ensure that both Part-I and Part-II of their tenders reach the Centre Director, CPP-IPR on or before the due date and time specified for their receipt to avoid the rejection of the tenders.

5.0 OPENING OF TENDERS

5.1 Unless otherwise pre-opened or postponed with advance intimation to the tenderers, tender will be opened in two stages on the date and time indicated in the tender notice.

5.2 Part-I (Techno-commercial) of the tender will be opened at the first stage on the due date and time indicated for opening in the tender notice of this tender document while the Part-II (Price) will be opened at the second stage after completion of the evaluation of the Techno-Commercial Part (Part-I) of the tender.

5.3 While all the tenderers who submit tenders within the due date and time specified for its receipt will be permitted to participate in the opening of Part-I (Techno-Commercial) of the tender on the due date and time indicated in the instruction sheet of this tender document, opening of the Part-II (Price) of the tender can be attended to only by such of those tenderers whose Part-I (Techno-commercial) of the tenders are found to be technical suitable/acceptable to the Purchaser and to whom intimation thereof is given by the Purchaser by Email/letter.

5.4 The tenderers whose Techno-commercial part (Part-I) are found suitable/acceptable to the Purchaser, will be given seven days advance intimation by the Purchaser to enable such tenderers to depute their representative to participate in the opening of the Part-II (Price) of the tender. The technically unqualified tenderers will neither be given any intimation about the due date and time of opening of Part-II (Price) of the tender nor will they be permitted to participate in the opening of the same. **Part-II (Price) of the technically disqualified tenderers will not be opened.**

6.0 AUTHORITY LETTER

6.1 The tenderers who wish to participate in the opening of the tenders may depute their representatives to IPR on the respective due date and time as indicated in the tender notice with an authority letter addressed to the Purchase Officer which should be produced to the officers who are opening the tenders, on demand to prove the bonafides of the representative who participates in the opening of the tender. In case the representative of the tenderer fails to produce such an authority letter on behalf of the tenderer, he will be debarred from participating in the opening of the tenders.

6.2 The tenderers representative, who reaches the venue of the tender opening late, i.e. after the starting time specified for opening of the tenders, may not be allowed to take part in the tender opening. It should be noted that only one representative of each tenderer will be permitted to participate in the tender opening.

7.0 TECHNICAL CLARIFICATIONS

7.1 After opening of Part-I (Techno-commercial) of the tender, if it becomes necessary for CPP-IPR to seek clarifications from the tenderers, the same will be sought for from the tenderers.

8.0 DATE FOR OPENING OF PART-II (PRICE):

After completion of technical evaluation, Part-II (Price) of only technically qualified tenderers shall be opened. The due date and time of opening of Part-II (Price) shall be intimated only to the technically qualified tenderers. Whose Part-I offers have been found suitable will only be permitted to participate in the opening of the Part-II (Price) of the tender.

9.0 HOLIDAYS

If the date(s) specified for receipt and opening of the tenders is/are declared as holidays abruptly by the competent authority due to any administrative reasons, then the due date(s) for receipt/opening of tenders will get postponed automatically to the next working day. As for instance, if the due date for receipt of tender and its opening falls on 3rd of a particular month and if the 3rd day of the month is declared as a holiday, then the opening date of tender will stand automatically postponed to 4th day of the month at the same time.

10.0 VALIDITY OF OFFERS

Offers shall be kept valid for acceptance for a period of 120 (One hundred twenty) days from the date of opening of Part-II (Price) of the tender. Offers with shorter validity period will be liable for rejection.

11.0 CATALOGUES/TECHNICAL LITERATURE

All necessary catalogues/drawings, technical literature data as are considered essential for full and correct evaluation of the offers shall invariably accompany the Part-I (Techno-Commercial) of the tender.

12.0 TERMS AND CONDITIONS OF THE CONTRACT

It must be clearly understood that any contract concluded pursuant to this invitation to tender shall be governed by the General Conditions of the Contract as contained in Section "B" of this tender document. Tenderers must therefore, take special care to go through these general conditions of contract and in exceptional cases if any deviations are proposed, these must be clearly indicated in the Part-I of the tender as a separate annexure instead of merely enclosing their printed conditions of Sale. Tenders made subject to counter conditions or far too many deviations from the general conditions of contract, i.e. Section "B" of this tender document are liable to be ignored. It should also be realised that failure to bring out deviations from the General Conditions of Contract contained in Section "B" of this tender document will imply that the tenderer is willing to execute the contract as per the Purchaser's terms and conditions of contract.

13.0 TENDERING CONDITIONS FOR BIDS

13.1 The prices quoted must be FIRM and preference will be given to such tenders. In exceptional cases (e.g. items involving substantial use of raw materials susceptible to sharp fluctuations in prices) if prices quoted subject to variation it shall be on the basis of a standard 'Price Variation Formula'. The basis for calculation shall be

very clearly stated. The responsibility for furnishing the documentary evidence for price variation lies with the vendor. Here again preference will be given to the tenders with a specific ceiling on escalation.

- 13.2 Prices quoted by the tenderer should include all charges involved for direct and safe-delivery of the stores to the consignee/place of delivery indicated in the tender document. If a tenderer so desires, separate lump sum charges for safe-delivery of the stores to the consignee/purchaser's site, could be furnished. However, the purchaser reserves the right to call for break-up. The purchaser will neither undertake responsibility for transit insurance nor pay for it separately.
- 13.3 In respect of tenders on Ex-works basis, in case the tenderer has not mentioned in the offer packing, forwarding and transportation charges for safe delivery up to Purchaser's site, 2% of the price quoted towards packing (in respect of both local and outstation firms), 1% of the basic price quoted towards safe delivery charges in respect of local tenderer and 3% of the basic price quoted towards safe delivery charges in respect of outstation firm will be added for comparison of offers on safe door delivery at Purchaser's site.
- 13.4 The stores shall neither be despatched under 'owner's risk' nor consigned to 'self', but only to the consignee's name and address indicated in the Purchase order. Non-adherence to this condition shall make the contractor liable to bear all consequential penalties/expenses such as demurrage, wharfage, etc. which the Purchaser may incur.
- 13.5 The consignee will, as soon as possible, but not later than 45 days from the date of arrival of stores at destination notify the contractor of any loss or damage to the stores that may have occurred during transit to enable the contractor to repair/rectify the defects/damages or replace the goods as is appropriate, free of all charges. In case it is desired by the contractor for returning of the material to them all expenses towards transportation etc. will be borne by the supplier and also will furnish bank guarantee towards the cost of material.
- 13.6 In case an Indian supplier/Agent furnishes an offer for supply of out-rightly imported stores, the price of such stores shall be quoted in Indian Rupees for delivery to the consignee's premises exclusive of import duties and on firm price basis. However, the percentage/quantum of all import duties payable should be quoted separately for consideration of the purchaser wherever necessary.
- 13.7 **Conditional Discount:** In case the tenderer offers any conditional discount with regard to acceptance of their offer within a specific payment terms, delivery, quantity etc. the purchaser will not take into consideration such conditional discount while evaluating their offer.

14.0 SPARES AND ACCESSORIES

- 14.1 Tenders for plant/machinery/equipment/component shall also indicate prices for essential accessories, optional accessories and spares necessary for satisfactory operation of the plant/machinery/ equipment.
- 14.1.1 for a period of two years and
- 14.1.2 for a period of five years
- 14.2 Prices for accessories and spares shall be itemized. Tenders where only lumpsum prices are indicated are liable to be ignored. Particular care must be taken to list out each item of spare and quantity recommended and also the individual price for these items. These details should be included only in Part-II (Price) of the tender. However, a list of spares and accessories without Price should be included in Part-I (Techno-Commercial) of the tender.

15.0 QUANTITY

The purchaser reserves the right to accept tenders for any quantity of his choice and the tenderer shall be bound to accept a contract for any quantity. The Purchaser also reserves the right to accept or reject lowest or any tender in full or in part without assigning any reasons.

16.0 STATUTORY LEVIES SUCH AS CUSTOMS DUTY, GOODS AND SERVICE TAX

16.1 CUSTOMS DUTY

- 16.1.1 The purchaser is entitled for assessment of Customs Duty at the concessional rate as per Customs Notification No.51/96-Custom dt. 23.7.1996, issued by the Department of Revenue, Ministry of Finance in respect of purchases made for the Research Institutions under the Department of Atomic Energy, and the purchaser will obtain and provide the requisite certificate from the appropriate authority for availing of the concessional rate of custom duty.
- 16.1.2 In case an Indian supplier/agent submits an offer for supply of out rightly imported stores in Indian Rupees, they should quote the price for CIF Port of Destination (like CIF Guwahati) exclusive of import duties and on firm price basis. However, the percentage/quantum of all import duties payable should be quoted separately for consideration of the purchaser wherever necessary. The transit insurance for the same should be taken from an Indian Insurance company nominated by the purchaser, so as to provide insurance coverage from anywhere in the world to anywhere in India.
- 16.1.3 Wherever, against a requirement, both indigenous as well as imported offers are received, the offers for imported stores will be evaluated on the basis of the total landed cost after loading the custom duty and other levies as may be applicable from time to time for taking purchase decision.
- 16.1.4 Customs Duty exemption certificate will not be issued for raw materials/components or any other intermediary materials going into the manufacture of the end product.

16.2 **Offers from Indian Agents on behalf of foreign suppliers:** In case the tender is submitted by an Indian supplier/Indian agent on behalf of their foreign supplier/principals, following documents should be submitted with the tender, failing which, their offer is liable to be ignored.

- 16.2.1 Photocopy of the Agency Agreement between the Principals and the Indian Agent showing the percentage or the quantum of agency commission payable and a Letter of Authority from the Principals authorizing the Indian Agents to submit the tender on their behalf.
- 16.2.2 The type and nature of after sales services to be rendered by the Indian Agent.
- 16.2.3 Both Indian Agent and Principal/OEM cannot bid simultaneously for the same item/product in the same tender.
- 16.2.4 The Indian Agents are allowed to quote on behalf of only one foreign Principal/ Supplier against this tender.
- 16.2.5 Copy of Registration Certificate with DGS&D or DPS.

16.3 GOODS AND SERVICE TAX

GOODS AND SERVICE TAX where legally liveable will be admitted and reimbursed at the rate applicable during original delivery period.

When GOODS AND SERVICE TAX is claimed as extra by the vendor in general, the following certificates should be submitted by the vendor to the Paying Authority on the bills itself: -

Certified that the GOODS AND SERVICE TAX charged has not been exempted under the GST Act or the rules made there-under and the amount charged on account of GST are not more than what is payable under the provision of relevant ACT or the rules there-under.

Certified further that we are being assessed to GST and also that where there are statutory exemptions under the Relevant Act/Law of the State

Government concerned, we have availed ourselves of it and certified non-availability of such a provision for GST wherever claimed.

Certified further in respect of amount claimed into the bill no claim is pending for refund/or admissible. Certified that in the event of our getting refund in whole or in part of the element of GOODS AND SERVICES TAX claimed from Government, we shall pass on the benefit to the Purchaser by remitting to Government the amount equivalent to the amount of refund obtained by us.

Certified further that we (our Branch or agent) _____ (address) are registered in the state of _____ under GST Regn. No. _____.

(Stamp & Signature of the Vendor)

The vendor shall solely be responsible for declaration of Goods and Service Tax made in his invoice and shall indemnify the purchaser from any claim or its liability from concerned authorities at any stage.

Certificate with each bill to the effect that no refund has been obtained in respect of the reimbursement of GST made to vendor during three months immediately preceding the date of the claim covered by the relevant bill.

AN UNDERTAKING to the effect that in case any refund of GST is granted to the vendor by concerned authorities in respect of stores supplied under the contract, they shall pass on the credit to the purchaser immediately along with a certificate from their Director/Manager/Proprietor/Accountant to the effect that the credit so passed on relates to the GST originally paid for the stores supplied under the contract. In case of their failure to do so within 10 days of the issue of the refund orders to them by the Authorities, the purchaser would be empowered to deduct a sum equivalent to the amount refunded by the authorities without any further reference to the vendor, from any of their outstanding bills against this or any other pending Government Contracts and that no dispute on this account would be raised by the vendor.

Vendor should provide GSTIN Certificate along with HSN code of the tendered item along with their quotation.

17.0 FLUCTUATION IN CUSTOMS DUTY

Unless otherwise specifically agreed to in terms of the Contract, the purchaser shall not be liable for any claim on account of fresh imposition and/or increase in Customs Duty on raw materials and/or components used directly in the manufacture of the contracted stores, taking place during the pendency of the contract.

18.0 SAMPLES/PROTOTYPES

If any called for shall be submitted free of all charges by the Tenderer and the Purchaser shall not be responsible for any loss or damage thereof for any reason whatsoever. In the event of non-acceptance of the tender, the tenderer will have to make arrangements to remove/collect the sample/prototypes at his own expenses.

19.0 QUANTITIES

Quantities indicated are approximate only and one or more of the items of the stores tendered, or a portion of any one or more of the items of such stores may be

accepted and the tenderer notwithstanding that his Tender has not been accepted in whole shall be bound to supply contracted quantity to the Purchaser.

20.0 SUBMISSION OF DRAWINGS

The tenderer shall furnish all drawings pertaining to the plant/machinery/equipment/component to the Purchaser along with the tender for correct understanding and appreciation of the tender in quadruplicate. Besides, tenderers should also furnish general arrangement, schematic and such other drawings prescribed by the Purchaser within 4 weeks from the date of receipt of a Purchase Order for approval. Such drawings should be furnished along with Part-I (Techno-Commercial) of the tender. Tenderer's drawing will form part of the purchase order/contract only after these are approved by the Purchaser.

21.0 INSTALLATION AND COMMISSIONING

- 21.1 Wherever, the purchaser's invitation to tender calls for installation and commissioning or supervision of installation and commissioning of the instrument/equipment by the tenderer, the tenderer must clearly and separately quote the prices for the supply of the stores and the charges and the terms for installation and commissioning or supervision of installation and commissioning, as the case may be. The charges towards installation and commissioning should not be included in the price of the stores.
- 21.2 In respect of contracts involving installation and commissioning by the overseas supplier where identifiable charges for the same has been quoted by the tenderer, he shall bear the Income-tax liability as per the prevailing DTAA rates at the time of undertaking the job in accordance with the Income Tax Act in force in India.
- 21.3 Wherever, the scope of the contract includes installation and commissioning, it shall be the sole responsibility of the contractor to undertake the installation and commissioning as and when called for, by the Purchaser.

22.0 INSPECTION

- 22.1 The Contractor shall be responsible for and perform all inspection and testing required in accordance with the contract/purchase order and specifications included therewith.
- 22.2 The Purchaser may at his option depute his representative for inspection of the stores to be supplied under the contract or authorize and nominate a Quality Surveillance Agency of his choice for the purpose hereinafter called, in either case, the inspection.
- 22.3 The supplier shall give notice of readiness for inspection to the Purchaser so that the Inspector can be present at the requisite time. In such an event delivery shall not be effected until an authorization or shipping release is obtained from the Purchaser.
- 22.4 The contractor shall allow reasonable facility and free access to his work/factory and records to the inspector for the purpose of inspection or for ascertaining the progress of delivery under the contract.

23.0 FACTORY REGISTRATION/SHOP & ESTABLISHMENT CERTIFICATE

The tenderers shall submit the copy of the Factory Registration/License or Shop & Establishment Certificate as applicable, along with the tender, failing which the tenders are liable for rejection.

24.0 PRODUCTS WITH ISI MARK

- 24.1 Products with ISI mark will be preferred.
- 24.2 In respect of following categories of item, Purchaser will consider offers for products with ISI mark only:

- Fire Extinguisher
- Building Material
- PVC Pipes & fittings
- Agricultural Implements & sprayers
- Medical instruments such as syringes, needles, BP apparatus etc.

25.0 SHOP/FACTORY EVALUATION, QUALITY SURVEILLANCE /INSPECTION AND SUBMISSION OF PROGRESS REPORTS

25.1 The Purchaser or his technical authorities may at his option and prior to evaluation of the tender depute his Inspector or any quality surveillance Agency of his choice to the factory/workshop of the tenderer to assess and establish the manufacturing capability etc. of the tenderer. Similarly, the Purchaser may also depute his inspector/Quality Surveillance agency of his choice for inspection of the plant/machinery/equipment/component during the various stages of manufacture in such an event the tenderer/contractor shall: -

25.1.1 Allow reasonable facility and free access to his factory/work/ records to the Inspector for the purpose of inspection or for ascertaining the progress of manufacture and delivery.

25.1.2 Provide the drawings, tooling, gauges, instruments etc. required for carrying out the inspection work.

25.1.3 Produce an inspection plan to the Purchaser's satisfaction notifying him when check points on the plan are imminent.

25.1.4 Not supply or deliver the plant/machinery/equipment/ component unless and until a Shipping Release or an authorization for despatch is obtained in a format provided by the Purchaser. Failure to comply with this instruction will not only result in with holding of the payment to the contractor/supplier, but also hold the tenderer/contractor liable for payment of compensation to the Purchaser due to delay in clearance of the Equipment/plant/machinery/ component from the carriers.

26.0 INSTRUCTION MANUAL

In respect of plant/ machinery/ equipment/ instrument/ apparatus, where instruction/ operation manual is normally necessary to enable the user to put the plant/machinery/equipment/instrument/ apparatus to proper use, the Contractor shall furnish such an instruction/operation manual specific to the stores being supplied along with the plant/machinery/equipment/instrument/apparatus. The Contractor shall clearly specify in the offer about his readiness to supply instruction/operation manual

27.0 PACKING

27.1 Tenderers shall note that packing for shipment shall be in accordance with the instructions outlined in this tender document, each package shall be limited to the size and weights that are permissible under the existing Air and Sea limitations. Even when no packing specification is included in the invitation to tender, it will be Supplier's responsibility to provide appropriate packing depending upon the nature of the supply and the transportation and handling hazards.

27.2 The equipment shall be so packed and protected as not to suffer deterioration, damage or breakage during shipment and storage in a tropical climate.

27.3 Each package shall be properly labelled to indicate the type and quantity of material it contains, the purchase order number, its dimensions and weight and any other necessary data to identify the equipment and relate it to contract.

28.0 DEVIATIONS TO PURCHASER'S SPECIFICATIONS AND CONDITIONS OF CONTRACT

- 28.1 If any deviation or substitution from the technical specifications contained in Section "C" to this tender document is involved, such details should be clearly indicated in Part-I (Techno-Commercial) and should be added as an annexure to Part-I (Techno-commercial) of the tender as otherwise it shall be an admission on the part of the tenderer that he will supply the equipment as specified by the Purchaser. Similarly, deviations to the Purchaser's General Conditions of Contract/Special Conditions of Contract contained in Section "B" of this tender document shall be indicated by the tenderer in another annexure to Part-I (Techno-commercial) of the tenderer.
- 28.2 Part-II (Price) should be furnished in accordance with the format provided by the Purchaser at Section "D" of this tender document.

29.0 DELIVERY

Tenderer should note that no tender will be considered by the Purchaser unless the Tenderer can meet the delivery schedule specified by the Purchaser. All equipment/machinery/plant/ component covered by this tender document should be supplied on or before 6 (Six) month from the date of Purchase Order. The prices quoted by the tenderer should include all charges involved for direct and safe delivery of the items by Road to the project site of the Purchaser. If a tenderer so desires/separate lumpsum charges for transportation and safe delivery to Purchaser's site could be furnished. Purchaser will neither undertake responsibility for transit insurance nor pay for it separately. No other, delivery term will be accepted by the Purchaser.

30.0 ACCEPTANCE OF TENDERS

Acceptance of tenders by the Purchaser will be sent by fax, E-mail, letter etc. within the validity date of the tender and such a fax, letter etc. would then be followed by a formal purchase order/contract. The tenderer whose offer is accepted will proceed with the execution of the contract on the basis of such advance acceptance of tenders without waiting for a formal purchase order/contract, and will be responsible to seek and obtain whatever clarifications that are necessary from the Purchaser to proceed with the manufacture without waiting for a formal purchase order/contract and delivery period will be reckoned from the date of the Letter of Intent.

31.0 SETTLEMENT OF COMMERCIAL TERMS AND CONDITIONS OF CONTRACT

In case the commercial terms and conditions of sale/contract stipulated in Part-I (Techno-commercial) of the tender submitted by the tenderer are at variance with the Purchaser's General Conditions of all Contracts/Special Conditions of Contract stipulated in Section "B" of this tender document, the Purchase Officer will settle the commercial terms and conditions of contract with the tenderers chosen for award of the contract by holding discussions with them OR by sending Fax/Letter/E-mail etc. In case the concerned tenderer to whom an intimation thereof is given does not respond/fail to respond to communication sent by the Purchaser within the date specified, his tender is liable for rejection at the discretion of Director, IPR and no complaints whatsoever will be entertained from the tenderer for rejection of this tender. The tenderers should not discuss with the technical authorities/user department any of the commercial terms and conditions of contract and any agreement/understanding reached between the tenderer and the technical authorities will not be valid and binding.

32.0 COMPLIANCE WITH THE SECURITY REQUIREMENTS OF THE PURCHASER

The Contractor shall strictly comply with the Security Rules and Regulations of the Purchaser in force and shall complete the required formalities including verification from Police and any other authority and obtain necessary prior permission for entry into the Purchaser's premises, wherever authorized by the Purchaser.

33.0 PAST PERFORMANCE

In case the past performance of the tenderer is not found to be satisfactory with regard to quality, delivery, warranty obligation and non-fulfilment of terms and conditions of the contract, their offer is liable to be rejected by the purchaser.

34.0 CAPACITY & FINANCIAL STANDING

In case it is found that the tenderer does not possess the requisite infrastructure, capacity, capability and their financial standing is not satisfactory, such tender is liable to be rejected by the Purchaser.

35.0 CONFIDENTIALITY

Drawings, specifications, prototypes, samples or any other correspondence/details/information provided by the Purchaser relating to the tender or the contract shall be kept confidential by the contractor, and should not be disclosed or passed on to any other person/firm without the prior written consent of the purchaser. This clause shall apply to the sub-contractors, consultants, advisers or the employees engaged by the Contractor.

36.0 RESTRICTED INFORMATION CATEGORIES UNDER SECTION 18 OF THE ATOMIC ENERGY ACT, 1962 AND OFFICIAL SECRETS UNDER SECTION 5 OF THE OFFICIAL SECRETS ACT, 1923

Any contravention of the above mentioned provisions by the contractor, sub-contractor, consultant, adviser or the employees of the contractor will invite penal consequences under the aforesaid legislation.

37.0 PROHIBITION AGAINST USE OF THE NAME OF ANY INSTITUTION OF DEPARTMENT OF ATOMIC ENERGY WITHOUT PERMISSION FOR PUBLICITY PURPOSES

The Contractor or sub-contractor, consultant, adviser or the employees engaged by the contractor shall not use the name of any Institution of Department of Atomic Energy for any publicity purpose through any public media like Press, Radio, TV or Internet without the prior written approval of the Purchaser.

38.0 FREE ISSUE MATERIAL *(This clause shall apply only to contracts for supply of fabricated equipment with purchaser's Free Issue Materials (FIM)).*

38.1 Wherever contracts envisage supply of Free Issue Material (FIM) by the Purchaser to the contractor, such Free Issue Material shall be safeguarded by an insurance policy to be provided by the Contractor at his own cost for the full value of such materials and the insurance policy shall cover, the following risks specifically and shall be valid for six months beyond the contractual delivery date.

- **Risk to be covered:** Any loss or damage to the Purchaser's material due to fire, theft, riot, burglary, strike, civil commotion, terrorist act, natural calamities etc. and any loss or damage arising out of any other causes such as other materials falling on purchaser's materials.

- **Insured by:** (Name of the Contractor)

- **Beneficiary:** Centre of Plasma Physics-Institute for Plasma Research, Nazirakhat, Sonapur-782402, Kamrup (M), Assam.

- **Amount for which insurance policy to be furnished:**

39.0 PURCHASE PREFERENCE

In respect of offers from Central Public Sector Enterprises, they will be eligible for purchase preference, if any, when they compete with the Private Sector Units as per the policy of the Government of India in force at the time of evaluation provided their offer is technically suitable.

40.0 PRICE PREFERENCE FOR MICRO & SMALL ENTERPRISES

In respect of offers from SSI units and Micro & Small Enterprises (MSEs) registered with appropriate Government authorities will be eligible for price preference, as admissible as per the policy of Government of India provided their offer is technically suitable.

41.0 PERMANENT ACCOUNT NUMBER

The tenderer shall submit a true copy of the PAN card/Letter issued by the Income-tax Department, along with the tender, failing which the tenders are liable for rejection.

SECTION 'B'

GENERAL CONDITIONS OF CONTRACT

**CENTRE OF PLASMA PHYSICS
INSTITUTE FOR PLASMA RESESARCH
PURCHASE SECTION**

**GENERAL CONDITIONS OF ALL CONTRACT
&
SPECIAL CONDITIONS OF CONTRACT
GOVERNING SUPPLIES OF
PLANT AND MACHINERY**

GENERAL CONDITIONS OF CONTRACT

1. DEFINITIONS

- 1.1 The term 'PURCHASER' means the Institute for Plasma Research or its successors or assigns.
- 1.2 The term 'PARTICULARS' means the following:
 - 1.2.1 Specification
 - 1.2.2 Drawing
 - 1.2.3 Sealed pattern denoting a pattern sealed and signed by the Inspector
 - 1.2.4 Proprietary make denoting the produce of an individual firm
 - 1.2.5 Any other details governing the construction manufacture and/or supply as existing for the contract.
- 1.3 The term 'CONTRACTOR' or 'SUPPLIER' means, firm or company with whom or with which the order for the supply of stores is placed and shall be deemed to include the Contractors/Successors (approved by the Purchaser), representatives, heirs, executors and administrators unless excluded by the contract.
- 1.4 The term 'CONTRACT' or 'PURCHASE ORDER' means and comprises of a Letter or Email or ink signed or digitally signed document conveying acceptance of Contractor's offer and invitation to tender, tender containing offer, advance acceptance of offer, general and special conditions of contract specified in the acceptance of offer and any subsequent amendments/alterations thereto made on the basis of mutual agreement.
- 1.5 The term 'STORES' or 'MATERIAL' means, the goods specified in the contract/purchase order which the contractor has agreed to supply under the contract.
- 1.6 The term 'SUB-CONTRACTOR' or 'SUB-SUPPLIER' means any contractor or supplier engaged by the contractor or the supplier with the prior approval of the Purchaser in relation to the contract/purchase order.
- 1.7 The term 'INSPECTOR' or 'QUALITY SURVEYOR' means any person nominated and deputed by the purchaser or their appointed Consultants or Quality Surveillance Agency or any other person from time to time authorized by the Purchaser to act as his representative for the purpose of inspection of stores under the contract/purchase order.

2. AUTHORITY OF PERSON SIGNING THE CONTRACT ON BEHALF OF THE CONTRACTOR

The person signing the contract or the purchase order or any other document in respect of the contract or purchase order on behalf of the contractor shall be deemed to warrant that he has the authority to bind the contractor.

3. SUBLETTING OF CONTRACT OR BILLS OR ANY BENEFIT ACCRUING THERE FROM

- 3.1 The Contractor shall not sublet, transfer or assign the Contract or any part thereof or bills or any other benefits, accruing therefrom or under the contract without the prior written consent of the Purchaser (All Sub-contractors are required to be appraised and approved by the Purchaser before placement of orders by the Contractor/Supplier). However, such consent shall not be unreasonably withheld by the Purchaser, if such stores are not normally manufactured by the Contractor, such assignment or subletting shall not relieve the Contractor from any contractual obligation or responsibility under the Contract.
- 3.2 Any breach of this condition shall entitle the Purchaser to cancel the Contract or any part thereof and to purchase from other sources at the risk and cost of the Contractor and shall recover from the Contractor damages arising from such cancellations.
- 3.3 In case the Contractor sublets, transfers or assigns any part of the Contract with the prior written consent of the Purchaser, all payments to the Sub-

Contractor shall be the responsibility of the Contractor and any requests from such sub-Contractor shall not be entertained by the Purchaser.

4. SECURITY DEPOSIT

- 4.1 On acceptance of tender, the Contractor shall at the option of the Purchaser and within the period specified by him, submit a Bank Guarantee from SBI or any one of the nationalized banks or reputed private banks, viz. AXIS Bank, ICICI Bank, IDBI Bank and HDFC Bank towards Security Deposit not exceeding 10% (ten percent) of the tendered value of the contract/purchase order valid till acceptance of the material, as the Purchaser shall specify.
- 4.2 If the Contractor is called upon by the Purchaser to submit Security Deposit and the contractor fails to provide the same within the period specified such failure shall constitute a breach of the Contract and the Purchaser shall be entitled to make other arrangements for the repurchase of the stores contracted for at the risk and expenses of the Contractor in terms of clause 10.2.4 hereof and/or recover from the Contractor damages arising from such cancellation. No claim shall lie against the purchaser either in respect of interest if any due on Security Deposit or depreciation in value.

5. SPECIFICATION, ETC.

5.1 Quality and Workmanship

- 5.1.1. The stores shall be of the best quality and workmanship and comply with particulars of the contract and in all respect shall be to the entire satisfaction of the Inspector and the Purchaser.
- 5.1.2. In particular and without prejudice to the foregoing conditions and in addition thereto when tenders are called for in accordance with 'particulars' Contractor's tender to supply in accordance with such particulars shall be deemed to be in admission on his part that he has fully acquainted himself with the details thereof and no claim on his part which may arise on account of non-examination of the 'particulars' will in any circumstances be considered by the Purchaser or be recoverable from him.

5.2 Contractor's Liability for Defective Stores

- 5.2.1 For a period of twelve months after the stores have been accepted by Purchaser the Contractor shall be responsible for any defects that may be discovered therein notwithstanding that such defects could have been discovered at the time of inspection or any defects therein are found to have developed under proper use, arising from faulty materials, design or workmanship and the Contractor shall remedy all such defects as aforesaid at his own cost provided he is called upon within a period of 14 months from the date of acceptance thereof to do so, by the Purchaser who shall state in writing in what respect the goods are faulty and further if in the opinion of the Purchaser the defects are of such a nature that it is necessary to replace or renew any defective stores, such replacement or renewal shall be made by the Contractor without any extra costs to the Purchaser, provided notice informing the Contractor of the defect is given by the Purchaser within the said period of 14 months. The decision of the Purchaser notwithstanding any prior approval or acceptance of the Inspector as to whether or not the stores delivered are defective or any defect has developed within the said period of twelve months or as to whether the nature of defects renewal or replacement shall be final conclusive and binding on the Contractor.

6. ALTERATION OF SPECIFICATIONS, PATTERNS AND DRAWINGS

- 6.1 The Purchaser reserves the right to alter, whenever necessary, specifications, patterns and drawings. As from the date, the Stores shall be in accordance with the specifications, patterns and drawings so altered, which the contractor is bound to comply with.
- 6.2 In the event of such alteration involving a revision in the cost, or in the delivery period, the same shall be discussed and mutually agreed to, taking into account the unit rates of similar items in the Contract. In case of disagreement, the decision of the Purchaser, in the cost or the delivery period, shall be final and conclusive.

7. SAMPLES

- 7.1 Samples submitted for any reason shall be supplied without charge and freight paid without any obligation of the Purchaser as regards safe custody or safe-return thereof. All samples submitted must be clearly labelled with the Contractor's name and address and tender number. If the Contractor submits the sample with his tender the same shall not govern the standard of supply except when it has been specifically stated in the Purchase Order that it is accepted instead of any sealed pattern. Should certified samples be lent to the Contractor by the Purchaser, the Contractor is responsible for the return in perfect order of all certified samples with the labels intact.

8. PACKING

- 8.1 The contractor shall be held responsible for the stores being sufficiently and properly packed for transport by rail, road, sea or air so as to ensure their being free from any loss or damages on arrival at their destination. The packing and marking of packages shall be done by and at the expenses of the Contractor. Each package shall contain a Packing Note quoting Purchase Order number and date and showing its contents in detail.
- 8.2 Unless otherwise provided in the contract all containers (including packing cases, boxes, tins, drums and wrappings) in which the stores are supplied by the contractor shall be considered as property of the Purchaser and their cost as having been included in the contract price.

9. CONTRACTOR'S RESPONSIBILITY REGARDING DESPATCH

- 9.1 **Said to contain basis:** The contractor shall be responsible for obtaining a clear receipt from the Transport Authorities specifying the goods dispatched, Purchaser shall not pay separately for transit insurance, all risks in transit being exclusively of the Contractor and the Purchaser shall pay for only such stores as are actually received by him in accordance with the Contract.
- 9.2 **Contractor's liability for freight and transport charges:** Unless otherwise expressly mentioned in the Purchase Order, the Contractor shall pay and bear all freights and all costs and expenses for transporting the stores to the place of delivery specified in the Purchase Order and the price specified in the Purchase Order shall be inclusive of all such freights, costs and expenses.
- 9.3 **F.O.R. Station of Despatch:** In the case of an 'F.O.R. station of despatch' contract, the stores shall be booked at full wagon rates whenever available and by the most economical route, and failure to do so will render the Contractor liable for the whole or part of any avoidable expenditure, caused to the Purchaser.

10. DELIVERY:

- 10.1 **Time for and date of delivery, the essence of the Contract:** The time for and the date of delivery of the stores stipulated in the purchase order shall be deemed to be the essence of contract, and delivery must be completed not later than the date specified therein.
- 10.2 **Failure and Termination:** Should the contractor fail to deliver the stores or any consignment thereof within the period prescribed for such delivery, the Purchaser shall be entitled at his option either:
 - 10.2.1 To recover from the Contractor as agreed liquidated damages and not by way of penalty, a sum of 2% of the price of any stores which the contractor has failed to deliver as aforesaid, for each month or part of a month, during which the delivery of such stores may be in arrears, or
 - 10.2.2 To recover from the Contractor, at the sole discretion of the Purchaser, token liquidated damages up to 10% of the normal liquidated damages may be imposed.
 - 10.2.3 Conditions under which Liquidated Damages will be levied are as under:

CONDITION	LEVY OF LIQUIDATED DAMAGES
i) Delay in supplies resulted in monetary loss actual/demonstrable and supplier was fully responsible for the delay.	Full Liquidated Damages will be levied as specified
ii) Delay in supplies resulted in monetary loss actual/demonstrable but the supplier was responsible only for part of the delay and remaining part of the delay was beyond their control and attributable to the purchaser.	Full Liquidated Damages will be levied as specified for which supplier is responsible.
iii) Delay in supplies resulted in monetary loss actual/demonstrable and entire delay was due to circumstances beyond their control and fully attributable to the Purchaser.	Liquidated Damages may be waived in full.
iv) Delay in supplies. However, monetary loss actual/demonstrable cannot be certified	Token Liquidated Damages equal of 10% of full Liquidated Damages will be levied.

- 10.2.4 To purchase or authorise the purchase elsewhere, without notice to the Contractor on the account and at the risk of the Contractor, the stores, not delivered or others of a similar description (where others exactly complying with the particulars are not, in the opinion of the Purchaser readily procurable, such opinion being final, readily procurable) without cancelling the contract in respect of the consignment(s) not yet due for delivery, or
- 10.2.5 To cancel the contract or a portion thereof, and, if so desired, to purchase or authorize the purchase of stores not so delivered or others of similar description (where others exactly complying with the particulars are not, in the opinion of the Purchaser readily procurable,

such opinion being final, readily procurable) at the risk and cost of the Contractor.

In the event of action being taken under clause 10.2.2, 10.2.3 or 10.2.4 above, the Contractor shall be liable for any loss which the Purchaser may sustain on that account, provided that the repurchase or, if there is an agreement to repurchase then such agreement, is made within six months of the date of such failure. But the contractor shall not be entitled to any gain on such repurchase made against default. The manner and method of such repurchase shall be in the entire discretion of the Purchaser, whose decision shall be final. It shall not be necessary for the Purchaser to serve a notice of such repurchase on the defaulting contractor. This right shall be without prejudice to the rights of the Purchaser to recover damages for breach of contract by the Contractor.

10.2.6 **Extension of time:** As soon as it is apparent that contract dates cannot be adhered to an application shall be sent by the contractor to the Purchaser. If failure, on the part of the Contractor to deliver the stores in proper time shall have arisen from any causes which the Purchaser may admit as reasonable ground for an extension of time (and his decision shall be final) he may allow such additional time as he considers it to be justified by circumstances of the case without prejudice to the Purchaser's rights to cover liquidated damages under **clause 22** hereof.

10.2.7 However, if the contractor fails to apply and secure extension of contract delivery dates before effecting the delivery of the supplies against the contract, acceptance of such stores by the Purchaser will in no way prejudice the rights of the Purchaser to levy the liquidated damages for delayed deliveries nor will it entitle the contractor for payment of statutory levies that come into force after the expiry of the contract delivery dates.

11. INSPECTION AND REJECTION

11.1 **Inspection and Rejection:** The stores shall be tendered by the Contractor for inspection at such places as may be specified by the Inspector, at the Contractor's own risk, expenses and costs and shall lie at such places of inspection at the risk of the Contractor and the stores will be subject to inspection and test as may be considered necessary by the inspector and his decision as regards rejection of goods shall be final and binding on the Contractor. If any goods are rejected as aforesaid, then without prejudice to the foregoing provision, the Purchaser shall be at liberty to

11.1.1 Allow the Contractor to re submit without prejudice to the Purchaser's right to claim and recover Liquidated damages as provided in clause 22 hereof, stores in replacement of those rejected within a time specified by the Purchaser (which time shall be essence of the contract), the contractor bearing the cost of freight for such replacement without being entitled to any extra payment, or

11.1.2 Buy the quantity of stores rejected or others of a similar nature elsewhere at the risk and cost of the Contractor in accordance with the provisions contained in second paragraph of clause 10.2.4 hereof without effecting the Contractor's liability as regards the supply of any further consignments due under the Contract, or

- 11.1.3 Terminate the Contract and recover from the Contractor the loss Purchaser thereby incurred
- 11.2 **Removal of rejection:** Any stores submitted for inspection and rejected by the Inspector must be removed by the Contractor within fourteen days from the date of receipt of intimation of rejection, provided that in the case of dangerous infected or perishable stores, the Inspector (whose decision shall be final) shall notify the Contractor to remove such stores within 48 hours of receipt of intimation of rejection and it shall be the duty of the Contractor to remove them accordingly. Such rejected stores shall lie at the Contractor's risk from the time of such rejection and if not removed within the aforementioned time, the Purchaser shall have the right either to return the rejected stores to the Contractor at the Contractor's risk by such mode of transport as Purchaser may select or to dispose off or segregate such stores as he thinks fit at the Contractor's risk and on his accounts and to appropriate such portion of the proceeds as may be necessary to cover any loss or expenses incurred by the Purchaser in connection with the said sale. Freight to destination of stores rejected after examination at destination shall be recoverable from the Contractor at the Tariff Rate.
- 11.3 **Test Certificate and Guarantees:** Test Certificate Guarantees, if required by the Inspector shall be obtained and furnished by the Contractor free of costs.

12. RECTIFICATION AND REPLACEMENT OF DEFECTIVE STORES

- 12.1 If the inspector find that the contractor has executed any unsound or imperfect work, the inspector shall notify such defects to the contractor and the contractor on receiving the details of such defects or deficiency, shall at his own expenses, within seven days or otherwise within such time as may be mutually agreed upon as reasonably necessary, proceed to alter, reconstruct or remanufacture the stores to the requisite standard and specifications as called for by the tender specification.

13. RECOVERY OF SUMS DUE

- 13.1 Whenever any claim for payment of, whether liquidated or not, moneys arises out of or under this contract against the Contractor the Purchaser shall be entitled to recover sum by appropriating, in part or whole, by encashing the Bank Guarantee submitted towards Security deposit by the Contractor, if a Security Deposit is taken against the Contract. In the event of the security being insufficient or no Security Deposit has been taken from the Contractor then the balance or the total sum or which at any time hereafter may become due to the Contractor under this or any other contract with the Purchaser, should this sum be not sufficient to cover the full amount recoverable, the Contractor shall pay to the Purchaser on demand the remaining balance due. Similarly, if the Purchaser has or makes any claim, 'whether liquidated or not against the Contractor under any other contract with the Purchaser the payment of all moneys payable under the contract to the contractor including the security deposit shall be withheld till such claims of the Purchaser are finally adjudicated upon and paid by the Contractor.
- 13.2 All demurrage, wharfage and allied expenses incurred by the Purchaser, if any, due to delayed clearance of Stores in view of non-receipt, incomplete or delayed receipt of documents by the Purchaser, shall be recovered from the payment due to the Contractor.

14. BAR/PERT CHART

- 14.1 The contractor at the discretion of the Purchaser shall submit the BAR/PERT chart indicating various activities from the date of purchase order to handing over of the stores.

15. PERFORMANCE BANK GUARANTEE

- 15.1 In the event of acceptance of the offer in respect of plant, machinery, equipment, instrument, etc. the tenderer will be required to submit a performance bank guarantee for 10% of the total value of the stores inclusive of all statutory levies and other charges admitted in the contract, from SBI/any nationalized bank or private sector banks, namely, ICICI Bank, IDBI Bank, HDFC Bank and AXIS Bank, on a non-judicial stamp paper of appropriate value valid till 2 months beyond the expiry date of warranty period as per the Purchaser's format towards satisfactory performance of the plant, machinery, equipment, instrument, etc. during the warranty period. In case of bids in currency other than INR performance bank guarantee shall be furnished from any bank of international repute.
- 15.2 In case of non-submission of performance bank guarantee by the Contractor, an amount equivalent to 10% of the total value of the stores and other charges admitted in the contract will be retained by the purchaser till the expiry of the warranty period of the stores.
- 15.3 Offers of the tenders who are not agreeable to furnish performance bank guarantee or retaining of an equivalent amount by the purchaser as per clause No.15.1 and 15.2 above, are likely to be rejected.

16. PERMIT AND LICENCES

- 16.1 The contractor shall secure and pay all licenses and permit at his end which he may be required to comply with all laws ordinances and regulations of the public authorities in connection with the performance of his obligations under the contract. The contractor shall be responsible for all damages and shall indemnify and save the purchaser harmless from against all claims for damages and liability which may arise out of the failure of the contractors to secure and pay for any such licenses and permits or to comply fully which any and all applicable laws ordinances and regulations.

17. PATENTS & PATENT RIGHTS INDEMNIFICATION

- 17.1 The Contractor shall indemnify and keep indemnified the Purchaser from and against any and all claims, actions, costs, charges and expenses arising from or for infringement of patent rights, copy right or other protected rights, of any design plans, diagrams, drawings in respect of the stores supplied by the contractors or any of the manufacturing methods or process adopted by contractor for the stores supplied under the contract.
- 17.2 In the event of any claim being made or action being taken against the purchaser in respect of the matter referred to clause 17.1 above, the contractor shall promptly be notified thereof and he shall at his own expense, conduct all negotiations for the settlement of the same and any litigation that may arise therefrom.
- 17.3 In the event of any designs, drawing, plans or diagrams or any manufacturing methods or process furnished by the contractor constituting infringement of patent or any other protected rights and use thereof is restrained, the contractor shall procure for Purchaser, at no cost to the latter, the rights to continue using the same or to the extent it is possible to replace the same so as to avoid such infringement and subject to approval by the Purchaser or modify them so that they become non-infringing, but such modifications shall otherwise be to the entire satisfaction of the Purchaser.

18. LAW GOVERNING THE CONTRACT

18.1 This Contract shall be governed by the laws of India for the time being in force. The marking of all stores supplied must comply with the requirements of India Acts relating to Merchandise Marks and all the rules made under such Acts.

19. JURISDICTION

19.1 The Courts within the local limits (i.e. Guwahati) of whose jurisdiction the place from which the purchase order is issued is situation only shall, subject to Arbitration Clause, have jurisdiction to deal with and decide any matter out of this Purchase Order/Contract.

20. SETTLEMENT OF DISPUTES

20.1 The Purchaser and the Contractor shall make every effort to resolve amicably by direct informal negotiation any disagreement or dispute arising between them under or in connection with the Contract.

20.2 If the parties have failed to resolve their dispute or difference by such mutual consultation, then either the Purchaser or the Supplier may give notice to the other party of its intention to commence arbitration, as hereinafter provided, as to the matter in dispute, and no arbitration in respect of this matter may be commenced unless such notice is given. Any dispute or difference in respect of which a notice of intention to commence arbitration has been given in accordance with this Clause shall be finally settled by arbitration. Arbitration may be commenced prior to or after delivery of the Goods under the Contract.

21. ARBITRATION

21.1 In the event of any dispute or difference arising out of or in connection with any of the terms and conditions of the Purchase Order/Contract, the matter shall be referred to the Centre Director, CPP-IPR for settlement. In case the parties to the Purchase Order are not in a position to settle the dispute mutually, the matter shall be referred to a Sole Arbitrator to be appointed in accordance with the Arbitration & Reconciliation Act, 1996 & Arbitration and Conciliation (Amendment) Act, 2015 as amended time to time.

22. LIQUIDATED DAMAGES

22.1 As per Standard Terms & conditions, the Purchaser reserves the right to levy the Liquidated Damages, for delay in supply beyond the contractual delivery date at the rate of 2% of the value of the stores the delivery of which is delayed, for each month or part of a month.

23. EXERCISING THE RIGHTS AND POWERS OF THE PURCHASER

23.1 All the rights, discretions and powers of the Purchase under the contract shall be exercisable by and all notices on behalf of the Purchaser shall be given by the Purchase Officer and any reference to the opinion of the Purchaser in the terms and conditions contained in these General Conditions of all Contracts shall mean and be construed as reference to the opinion of any of the persons mentioned in this clause.

24. TRAINING

- 24.1 The successful tenderer shall, if required by the Purchaser, provide facilities for the practical training of Purchaser's engineering or technical personnel for their active association on the manufacturing process throughout the manufacturing period of the Contract/stores, number of such personnel to be mutually agreed upon. If demanded by the Purchaser, such training shall be conducted at Purchaser's site by the Contractor free of charge. The duration of training shall be mutually decided upon by the Purchaser and the Contractor.

25. PRICE VARIATION

- 25.1 The prices quoted must be FIRM and preference will be given to such tenders. Prices charged by the supplier for the goods supplied and the services performed under the contract shall not vary from the prices quoted by the supplier in its bid with the exception of any price adjustment authorized in the Schedule of Requirements.
- 25.2 In exceptional cases (e.g. items involving substantial use of raw materials susceptible to sharp fluctuations in prices) if prices quoted subject to variation it shall be on the basis of a standard 'Price Variation Formula'. The basis for calculation shall be very clearly stated. The responsibility for furnishing the documentary evidence for price variation lies with the vendor. Here again preference will be given to the tenders with a specific ceiling on escalation.

26. RISK PURCHASE

- 26.1 In the event supplier fails to fulfill the contractual obligations as per the terms and conditions of the Contract, the Purchaser has an option of completing the Contract at the risk and expenses of the Contractor. While initiating risk purchase at the risk and expenses of the supplier, the Purchaser must satisfy himself that the supplier has failed to deliver and he has been given all the opportunities as per the Contract to execute the Contract and also adequate and proper notice. Wherever risk purchase is resorted to, the supplier is liable to pay the additional amount spent by the government, if any as compared to contracted amount. All the factors including the method of recovering such amount should also be considered while taking a decision to invoke the risk purchase.

27. LIEN IN RESPECT OF CLAIMS IN OTHER CONTRACTS

- 27.1 Any sum of money due and payable to the Contractor under any contract may be withheld or retained by way of lien by the purchaser or any other person or persons contracting through the Director, IPR against any claim of the Purchaser or such other person or persons in respect of payment of a sum of money arising out of or under any other contract made by the contractor with the Purchaser or with other such person or persons.
- 27.2 It is an agreed term of the contract that the sum of money so withheld or retained under this clause by the Purchaser will be kept withheld or retained as such by purchaser till this claim arising out of in the same contract or any other contract is either mutually settled or determined by the arbitrator, and that the contractor shall have no claim for interest or damages whatsoever on this account or on any other ground in respect of any sum of money withheld or retained under this clause and duly notified as such to the contractor.

SPECIAL CONDITIONS OF CONTRACT GOVERNING SUPPLIES OF PLANT AND MACHINERY

In addition to the General Conditions of Contract hereinbefore set out the following special conditions shall apply to contracts for the supply of Plant and Machinery and manufactured equipment. These Special Conditions where they differ from the General Conditions shall override the later.

28. DEFINITION OF PLANT

28.1 The word "PLANT" wherever, appears in these "Special Conditions of Contract governing supplies of Plants and Machinery" shall mean all machinery, plants, equipment or parts thereof or what the Contractor agrees to supply under contract as specified in the Purchase Order.

29. MISTAKES IN DRAWING

29.1 The Contractor shall be responsible for and shall pay for an alterations of the works due to any discrepancies, errors or omissions in the drawings or other particulars supplied by him whether such drawings or particulars have been approved by the Purchaser or not.

30. RESPONSIBILITY FOR COMPLETENESS

30.1 Any fittings or accessories which may not be specifically mentioned in the specification but for which are usual or necessary, are to be provided by the Contractor without extra charge and the plant must be complete in all respects.

31. REJECTION OF DEFECTIVE PLANT

31.1 If the plant after the acceptance thereof be discovered to be defective, notwithstanding that such defects could have been discovered at the time of inspection, or found to have failed to fulfil the requirements of the contract or developed defects after erection within a period of 12 months from the date of erection, whether such erection is done by the Purchaser or by the Contractor, the Purchaser shall be entitled to give a notice on the contractor setting forth details of such defects or failure and the contractor shall, provided such notice is given within a period of 14 months from the date of such erection or acceptance, forthwith make the defective plant good or alter the same to make it comply with the requirements of the contract at his own cost and further if in the opinion of the Purchaser, the defects are of such a nature that the defects cannot be made good or required without impairing the efficiency or workability of the plant or if in the opinion of the Purchaser the Plant cannot be repaired or altered to make is comply with the requirements of the Contract, the Contractor shall, provided a notice is given by the Purchaser in this behalf within a period of 14 month from the date of erection or acceptance thereof, remove and replace the same within plant conforming to the stipulated particulars in all respect at the Contractor's own cost. Should he fail to do so within a reasonable time, the Purchaser may reject at the cost of the contractor the whole or any part of the Plant as the case may be which is defective or fails to fulfil the requirements of the contract. Such replacement at the cost of the Contractor shall be carried out by the Purchaser within a reasonable time which plant of the same particulars or when the plant conforming to the stipulated particulars are not in the opinion of the Purchaser readily procurable, such opinion being final, then the nearest substitutes.

- 31.2 In the event of such rejection the Purchaser shall be entitled to use the plant in reasonable and proper manner for a time reasonably sufficient to enable him to obtain replacement as hereinbefore provided.

32. INSPECTION AND FINAL TESTS

- 32.1 All tests necessary to ensure that the plant complies with the particulars and guarantees shall be carried out at such place or places as may be determined by the inspector. Should, however, it be necessary for the final tests as to performance or guarantees to be held over until the Plant is erected at site they shall be carried out within one month of completion of erection.

33. TRANSPORT AND RESPONSIBILITY FOR BREAKAGES EN-ROUTE

- 33.1 Unless otherwise specified the Purchaser will take delivery of the plant from the place named in the purchase order but the contractor will be responsible for any damage which may be caused to the Plant during transit to the site of erection thereof.

34. INTIMATION ABOUT DELIVERY

- 34.1 If the Purchaser shall have notified the Contractor in writing that the former is not ready to take delivery, no plant or materials shall be forwarded until an intimation in writing shall have been given to the Contractor by the Purchaser that he is ready to take delivery.

35. ERECTION AND COMMISSIONING

- 35.1 In all cases where contracts provide for supervision of erection and commissioning or for test at the Purchaser's premises the Purchaser except where otherwise specified, shall provide free of charge, such labour, materials, fuels, stores, apparatus and instruments as may be required from time to time and as may reasonably be demanded by the contractor to carryout efficiently such supervision of erection and commissioning and for the requisite test. In case of contracts requiring electricity for the completion of erection, commissioning and testing at site, such electricity shall be supplied free to the contractor.

36. WARRANTY

- 36.1 For a period of twelve calendar months after the plant/machinery/equipment/instruments has been put into operation (or a suitable mutually agreed longer period to be reckoned from the date of last major shipment depending upon the nature of the plant/machinery/equipment/instrument) the Contractor shall be responsible for any defects that may develop under conditions provided for the contract and under proper use, arising from the faulty materials, design or workmanship in the plant or from faulty erection of the plant by the Contractor, but otherwise and shall rectify such defects at his own cost when called upon to do so by the Purchaser who shall state in writing such defects. An additional warranty of at least six months is desirable at free of cost.
- 36.2 If it becomes necessary for the Contractor to replace or renew any defective portions of the plant for purpose of rectification under this clause, the provisions of this clause shall apply to the portions of the plant so replaced or renewed under the expiration of six months from the date of such replacement or renewal or until the end of the above mentioned period of twelve months whichever may be the later. If any defects not rectified within reasonable time, the purchaser may proceed to get the work done at contractor's risk and expenses but without prejudice to any other rights which the Purchaser may have against the Contractor in respect of such defects as provided in clause 10.2.4 or 10.2.5.

- 36.3 All inspections adjustments, replacements or renewals carried out Contractor during the warranty period shall be subject to the same conditions as in the contract.
- 36.4 Contractor shall, spare parts of equipment before going out of production, give adequate advance notice to the purchaser so that the latter may order requirement of spares in one lot if so desires.
- 36.5 The contractor shall further guarantee that if spare parts go out of production, will make available blue prints, drawings of spare parts and specifications of material at no cost to the Purchaser, if and when required in connection with the equipment to enable Purchaser to fabricate or procure spare parts from other sources.
- 36.6 The provision of this clause shall remain effective and binding upon the Contractor even after the completion or expiration of the contract and till the plant/machinery/equipment supplied under the contract is in use by the Purchaser.

37. MODE OF PAYMENT

- 37.1 Unless otherwise agreed to in writing between the Purchaser and the Contractor, payment for the delivery of the material will be made as follows.
Within 30 days from the date of final acceptance and on receipt of Performance Bank guarantee for 10% of the contract value amount from SBI/nationalized banks or any one of the scheduled banks mentioned in the bracket (Axis Bank, HDFC Bank, ICICI Bank and IDBI Bank) valid throughout the guarantee period mentioned in the contract/purchase order.
- 37.1.1 In case any of the vendors seek advance or progressive payment prior to delivery of the material, such requests can be considered only in exceptional cases of large value items, in which case the vendor will be required to furnish a bank guarantee for an equivalent amount of the advance/progressive payment sought for, valid till the execution of the contract. The bank guarantee shall be got executed as per the Purchaser's format from the State Bank of India (SBI)/nationalized banks or any one of the scheduled banks mentioned in the bracket (Axis Bank, HDFC Bank, ICICI Bank and IDBI Bank).
- 37.1.2 Besides, the offers of the vendors seeking advance/progressive payment will be evaluated by loading 12% interest charges per annum on the amount of advance desired up to the delivery period quoted.
- 37.1.3 In case any of the vendors seek pro-rata payment for the stores to be supplied they should clearly mention in their offer the maximum number of instalments of supply. However, such instalment delivery and pro-rata payment will be considered only in respect of contract involving large value and sizeable quantity of the item and the maximum number of instalments shall be normally restricted to four. Acceptance or otherwise of this condition is reserved by the purchaser.
- 37.1.4 **Bank Charges:** All bank charges to be borne by the Contractor/Supplier.
- 37.1.5 No correspondence will be entertained within 30 days from the date of receipt of material and bills, whichever is later.
- 37.1.6 **Interest for delay in supply beyond the contractual delivery date:** Wherever advance payments are sought for by the contractor and admitted in the contract, against Bank Guarantee for equivalent amount, in the event of any delay in supply beyond the contractual delivery date for reasons attributable to the contractor, interest charges @ 12% shall be levied for the period beyond the contractual delivery date, on the amount of balance advance payment to be adjusted.

38. DELAY IN ERECTION

38.1 Wherever erection of a plant or machinery is the responsibility of the Contractor as a term of the contract and in case the Contractor fails to carry out the erection as and when called upon as to do within the period specified by the Purchaser, the Purchaser shall have right to get the erection done through any source of his choice. In such an event, the contractor shall be liable to bear any additional expenditure that the Purchaser may incur towards erection. The Contractor shall, however, not be entitled to any gain due to such an action by the Purchaser.

SECTION 'C'

**TECHNICAL SPECIFICATIONS OF FIBRE OPTICS
LINKS MODULE [TRANSMITTER AND RECEIVER
(TX & RX)] IN NEGATIVE HYDROGEN ION
EXTRACTION FACILITY AT CPP-IPR**

Technical Specification of Fibre Optics Link Module:

Serial No	Item/Signal	CPP-IPR Specification
1	No of floating signals	51
2	Analog input voltage	±10 V or 4 -20mA
3	Analog output voltage	±10 V or 4 -20mA
4	Digital Input Voltage	0-5V TTL
5	Digital Output Voltage	0-5V TTL
6	Channels	Uni-directional analog and digital signals
7	Sampling Rate	10 kHz
8	Bandwidth of transmitter and receiver.	Analog Bandwidth: DC to 10 kHz or higher Digital Bandwidth: DC to 25 kbps or higher
9	Resolution	12 bit or more
10	Power Supply	Necessary Linear low noise regulated Power Supplies should be supplied to feed the FO modules. Power ratings of the supplies should be such that it delivers sufficient power to drive all the modules at specified voltage ratings of the modules.
11	Dimension	Should fit in 19-inch rack.
12	Mode of transfer	Multimode
13	Signals	51 Nos of floating signals. Please refer attached signal list. Out of which Digital-Input(DI)= 19 Digital-Output(DO)=11 Analog-Input(AI) =11 Analog-Output(AO)=10
14	Length of the fibre optics cables	At least 20 meters with all necessary connectors as per the requirement of 51 numbers of Floating channels mentioned in the attached signal list.

Special condition:

All the items have to follow or to be certified for the safety norms set by standard international/national quality control agency. This will include the safety for electrical, electromagnetic, environment friendly, nontoxic substances and non-explosive substances.

Quantity Required:

Supply of Fiber Optics Links Module [Transmitter and Receiver (TX & RX) modules] at Negative Hydrogen Ion Extraction facility at CPP-IPR. As per the floating channels mentioned in the signal list.

Acceptance Criteria:

1. The party may be asked (if felt necessary) for a test piece to check before placing the order.
2. The party should enclose a printed catalogue of the product along with the quotation, which contain the details required.
3. All the technical details should be supplied along with the quotation.
4. The vendor should submit test report of product/product type, test certification for electromagnetic, electric, non-toxic, non-explosive safety norms provided by reputed national/international testing agency. It should be compatible to use in electromagnetic environment.
5. CPP-IPR will issue a dispatch clearance based on the test report.
6. It should be noted that the vendor, to whom the purchase order will be placed, has to provide installation, commissioning and demonstration of items at CPP-IPR after the delivery of the item to the CPP-IPR.
7. The functionality of all the deliverable Hardware and software should be demonstrated by the vendor for their healthiness/proper operation at Site.
8. Final Acceptance will be given after satisfactory installation of hardware and software and their demonstration.
9. All the required instruments, accessories, cable and cabling other than the deliverable 'bill of materials' which are required from CPP-IPR for the satisfactory demonstration of the system has to be identified and listed and should be mentioned as the scope of CPP-IPR, Sonapur, while quoting. Those items not specifically identified as "scope of CPP-IPR" should be provided by the vendor towards completion of the project.
10. Once the operational behaviours are as per the experimental needs and satisfaction, the FAT (Factory Acceptance Test) will be cleared and then the party will be asked to ship the consignment considering all the necessary insurance and freight etc. issues.
11. All the tests that are done in FAT must be again repeated in Site acceptance tests (SAT) where after proper functioning of the already tested emulated signals, real time signals may be applied with caution to ensure the ranges of inputs within limits. All the necessary fine tunings should be undertaken during this period. The various reports should be updated with latest changes being done during commissioning of the system to have fully updated documentation.
12. The supplier should bring the necessary connectors/converters in order to meet the signal integrity, both output & input.
13. The items that will be received from the vendor in CPP-IPR should be unpacked in front of CPP-IPR representatives. A record of documentation will be done for above work.

Compliance Sheet for Fibre Optics Links Module [Transmitter and Receiver (TX & RX)]: -

Serial No	Item/Signal	CPP-IPR Specification	Vendor Specification
1	No of floating signals	51	
2	Analog input voltage	±10 V or 4 -20mA	
3	Analog output voltage	±10 V or 4 -20mA	
4	Digital Input Voltage	0-5V TTL	
5	Digital Output Voltage	0-5V TTL	
6	Channels	Uni-directional analog and digital signals	
7	Sampling Rate	10 kHz	
8	Bandwidth of transmitter and receiver.	Analog Bandwidth: DC to 10 kHz or higher Digital Bandwidth: DC to 25 kbps or higher	
9	Resolution	12 bit or more	
10	Power Supply	Necessary Linear low noise regulated Power Supplies should be supplied to feed the FO modules. Power ratings of the supplies should be such that it delivers sufficient power to drive all the modules at specified voltage ratings of the modules.	
11	Dimension	Should fit in 19-inch rack.	
12	Mode of transfer	Multimode	
13	Signals	51 Nos of floating signals. Please refer attached signal list. Out of which Digital-Input(DI)= 19 Digital-Output(DO)=11 Analog-Input(AI) =11 Analog-Output(AO)=10	
14	Length of the fibre optics cables	At least 20 meters with all necessary connectors as per the requirement of 51 numbers of Floating channels mentioned in the attached signal list.	

SECTION 'D'

FORMAT FOR SUBMISSION OF PART-II (PRICE)

Section-D**PART-II****PRICE BID FORMAT***(Bidders are requested to offer their price in the following format)*

Sr. No.	Description	Qty units	Basic rate (In Rs)	Packing & Forwarding (In Rs)	Applicable GST (In Rs)	Rate (Incl. P&F and GST) (In Rs)	Total Amount (In Rs)
		(a)	(b)	(c)	(d)	(e)= b+c+d	(f)= a x e
01	Fiber Optics Links Module [Transmitter and Receiver (TX & RX)] for Negative Hydrogen Ion Extraction facility at CPP-IPR	For 51 Nos of Floating Unit as per the signal list					
Total (Ex works/FCA in case of foreign vendor)							
Freight (in case of Indian vendor)							
Insurance (in case of Indian vendor)							
Grand Total							

Amount in words:

Description	Vendor Terms
Delivery terms	
Warranty	
Payment	
Delivery schedule	
Validity	
Any other terms	

Place:

Signature of Bidder with seal

Date:

TENDER FORM

Telephone Nos. :

Tenderer's Offer No.

Date _____

PART-II (PRICE)

Tender No. **CPP-IPR/TPT/TN/PUR/2017-18/29 DATED 02/08/2018**

Fax No. :

E-mail :

FROM

M/s. _____

To
The Centre Director,
Centre of Plasma Physics
Institute for Plasma Research
Nazirakhat, Sonapur-782402, Kamrup (M)
Assam, INDIA

Dear Sir,

In response to your invitation and as per your tendering and contracting conditions, the price and other related commercial conditions applicable for the scope of supply contained in Part-I (Techno-Commercial) of our tender are indicated in the format at annexure "A" to this tender.

We hereby agree to abide by your terms and conditions of contract contained in section "B" of this tender document. Deviations to your contract conditions are brought out separately in Annexure "B" to this tender.

We hereby agree to keep the price valid for your acceptance for a period of 180 days from the date of actual opening of Part-II (Price) of the tender.

Yours faithfully,

Stamp and Signature of the Tenderer

Brief description about “Extraction of negative hydrogen ions produced by Cesium coated tungsten dust”.

1. Introduction to the Experimental Setup for Negative Hydrogen Ion Extraction

In CPP-IPR negative hydrogen ion (H⁻ ion) source, tungsten dust particles are dropped from the top of the dust coating chamber, which is placed vertically above the plasma chamber. These dust particles are then coated *in-situ* by cesium (Cs) vapor coming out from Cs oven placed below the dust dropper. When energetic H atoms and H⁻ ions bombard the surface of Cs coated tungsten dust (low work function material), they get reflected in the form of H⁻ ions. The ions come isotropically from the plasma volume close to the grid hole and then the H⁻ ions are extracted through the plasma grid. Magnets of high field strength are placed at the extraction grid to prevent the electrons and allow only H⁻ ions to pass. Hydrogen plasma is produced in the plasma chamber by filament discharge method at low pressure (~10⁻⁴ mbar) and plasma thus produced is confined by full line cusp magnetic cage. The ion source is floated with respect to the extraction chamber with a potential difference of 30 kV DC. The grids, namely plasma grid, extraction grid (15 kV DC) and acceleration grid (15 kV DC) are placed in the grounded extraction chamber. A Faraday cup is placed near the acceleration grid to measure the beam current. A view of the experimental setup is shown in Fig. 1.

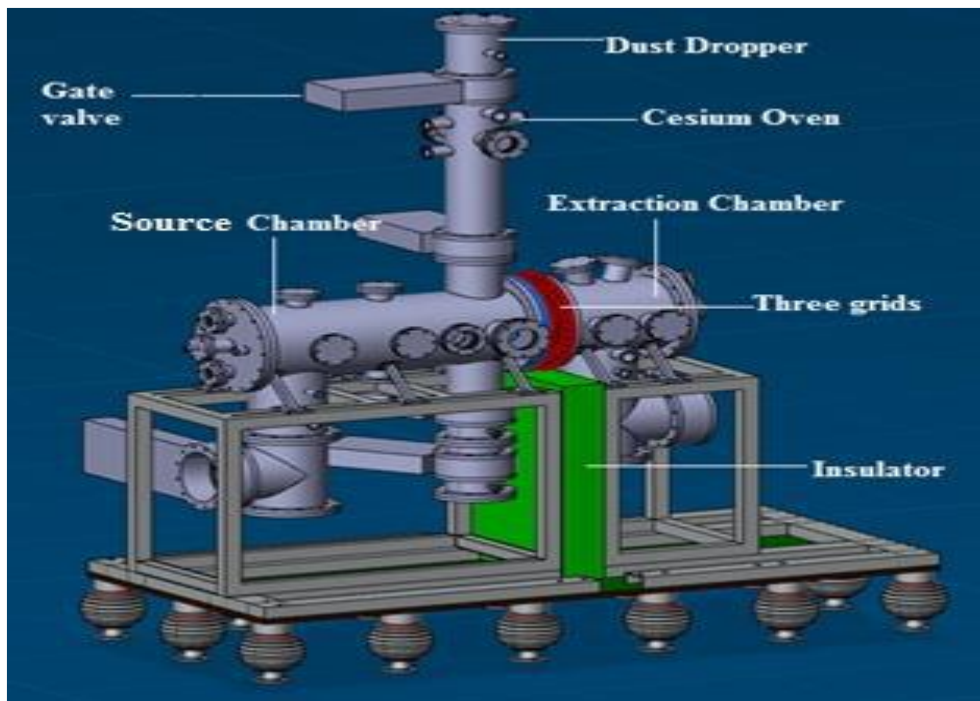
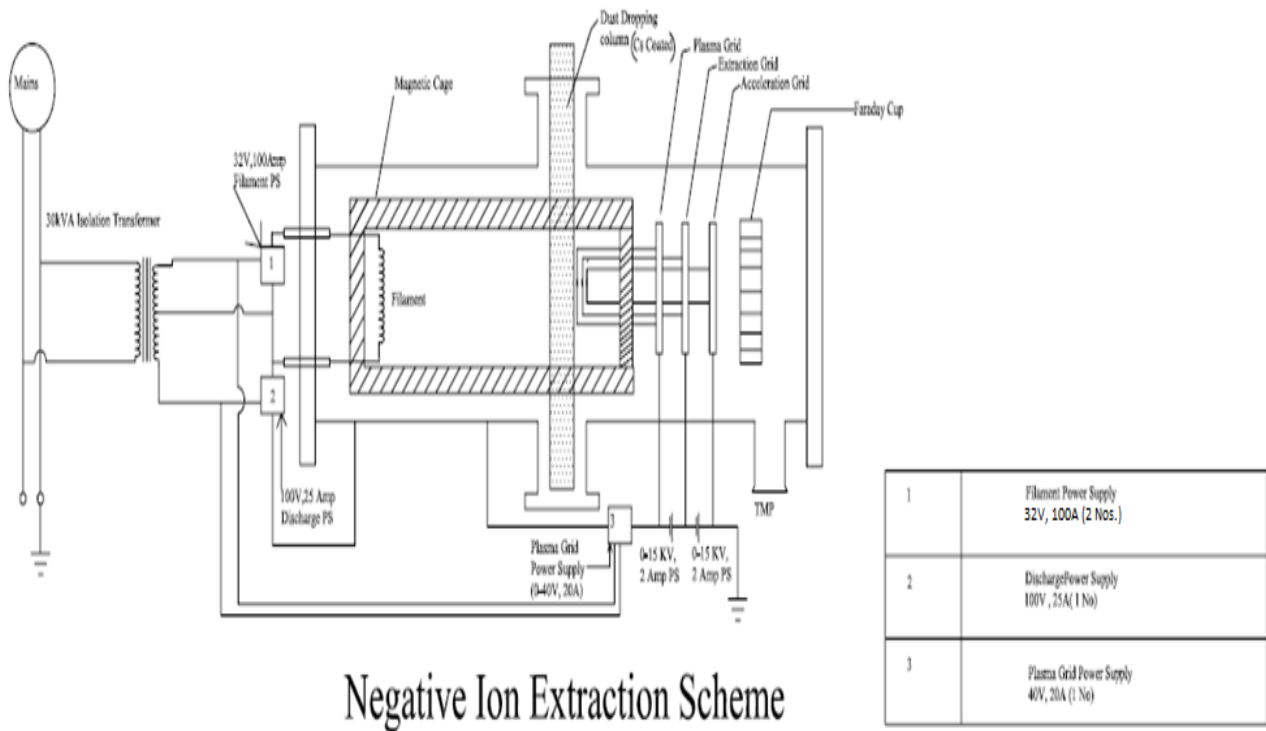

Fig. 1: View of the experimental setup

This tendering is for the Design and Implementation of Data Acquisition and Control System for Negative Hydrogen Ion Extraction Test Facility at CPP-IPR. Vendor will have to submit hardware design and engineering design based on preliminary hardware design provided by CPP-IPR for Data Acquisition and Control System for this Test Facility set-up along with the tender. After evaluation of hardware design and engineering design, CPP IPR will provide technical acceptance and will evaluate technical bid along with price bid for installation and commissioning of final system. The system will consist of PXI based simultaneous/sequence control unit and safety system, Real Time control loop, Data Acquisition with Real Time visualization, off line data analysis, online data analysis and diagnostic systems facility.



Negative Ion Extraction Scheme

Fig. 2: Schematic diagram of the negative ions extraction scheme

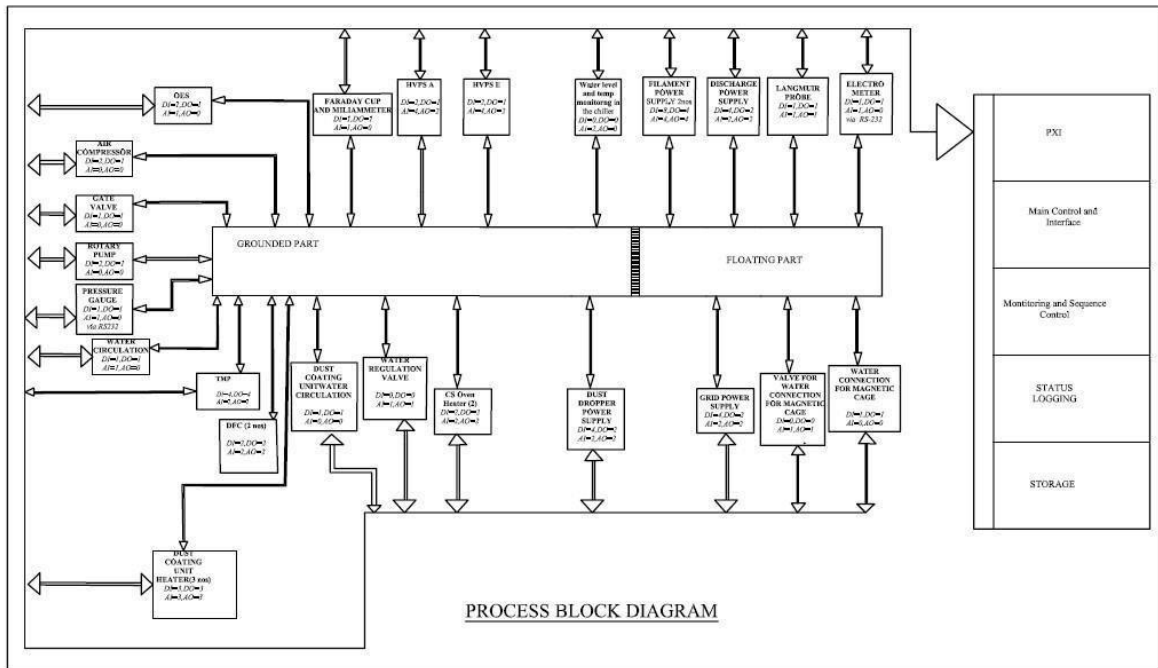

Fig. 3: Process Control Block Diagram

2. Data Acquisition (DAQ) and Control system

2.1 Main components of DAQ and Control System Main control and interface

- PXI based real time Control loop, Fast acquisition, Sequential operations, Safety interlocks and monitoring
- Fast interlocks and slow interlocks
- Desk Console for Operation with two monitors one for controlling and one for monitoring respectively.

2.2 Sequential control system

The operations sequence between the different states of experiment are described in following States

➤ S0 –state (OFF):

In this condition, all the subsystems of the floating part of the negative Hydrogen Ion Extraction system are in switched OFF condition. The essential systems like water cooling for TMP, gate valves, vacuum pumping system (Rotary pump), DAC and instrumentation may be ON and operative in this state. In this state all subsystems can be accessed for maintenance and servicing. All the subsystems should be connected to local earth for human safety.

➤ S1 – state (vacuum system ON):

In this state, the following subsystems should be in operational state. The system systems are:

- (i) Water cooling system for the chamber and the magnetic cage
- (ii) Air compressor
- (iii) Pressure monitoring systems
- (iv) Water conditioning and chiller temperature monitoring
- (v) All kind of Safety interlock (Ground loop Detection, Ground check, Door interlock, Access control System)
- (vi) AC mains distribution systems
- (vii) Low power electronics, processors, and DAC systems
- (viii) Vacuum pumping system (TMP)
- (ix) Gas Feeding System
- (x) Real time monitoring system is enabled

Operation related to Negative Hydrogen Ion Extraction System

➤ S2 – state (Filament ON):

In this state-

- (xi) Switched ON the mains of Filament and Discharge power supplies
- (xii) Power Supplies for the filaments are turned ON
- (xiii) Filament voltage is raised to appropriate values with pre-defined value
- (xiv) Discharge Power Supply is turned ON if the filament is OK and set the value
- (xv) Langmuir Probe to acquire I-V is ON

➤ S3 – state (Dust Unit Heater ON):

In this state-

- (xvi) Switched ON the mains of dust dropper power supply
- (xvii) Dust Dropper Power Supply should be switched ON.
- (xviii) Dust Coating Unit Heater On (200 °C)
- (xix) Dust Coating unit water circulation On
- (xx) Cs oven heater On (200 °C)
- (xxi) Electrometer On

➤ S4 – state (HVPS DC ON):

In this state-

- (xxii) High Voltage Power Supplies for both extraction and Accelerating Grid voltage is set at an operational level
- (xxiii) Faraday Cup with mill ammeter is turned ON to measure the beam current
- (xxiv) Fast data acquisition system should have selected for acquire mode.
- (xxv) Power Status On signal is generated and send to Real time controller.

Here each step is checked before releasing the next one. To ensure proper status of the subsystem, related operating parameter is checked by measuring the respective output signal and comparing it with the predefined references.

During the fault, the system is switch back to the next lower state that is supposed to be safe i.e. S4 → S3 → S2 → S1 → S0

On the S4 (HVPS ON) state, the source, the extraction system and associated sub-systems are at the top protection level that ensures a safe and reliable operation at the set power level. Only fatal failures will lead to a trip of whole system.

The Next lower state is ON state (S3 and S2) where all operational parameter is set. Any fault within this state will lead to trip or a switch back command depending on the faulty parameter. Sequential state

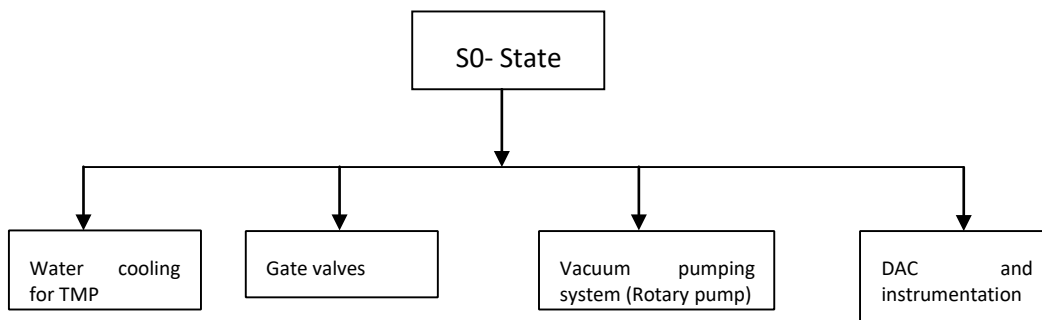

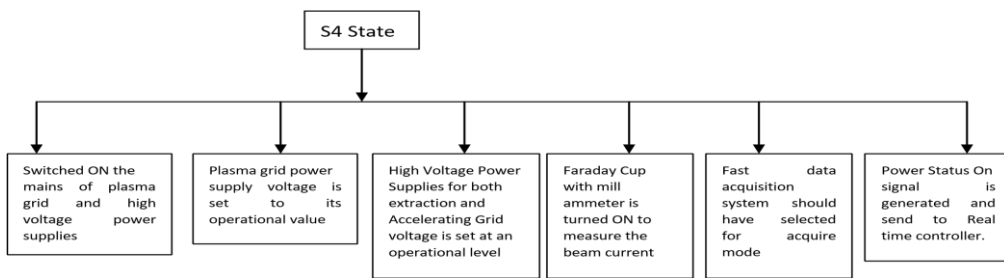
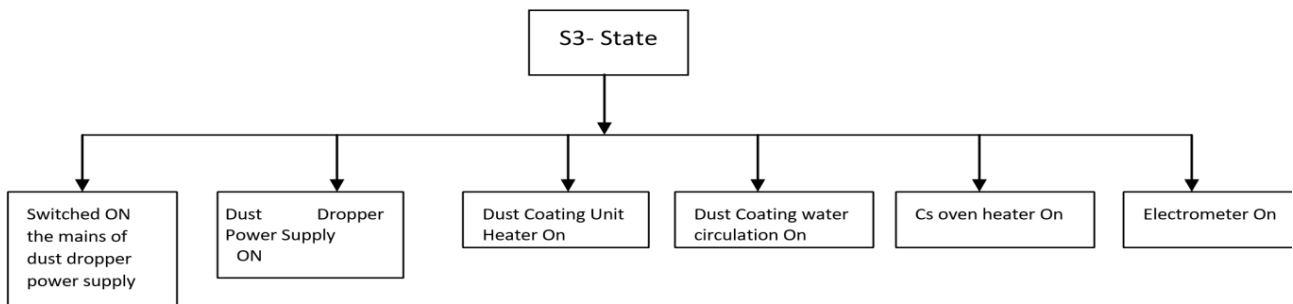
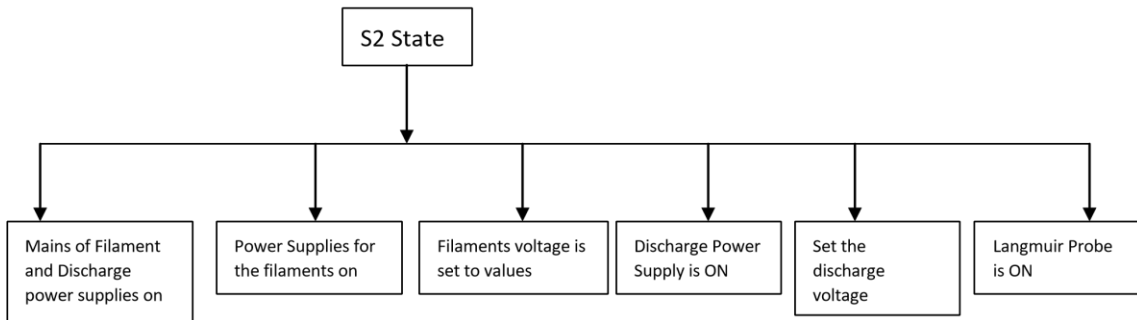
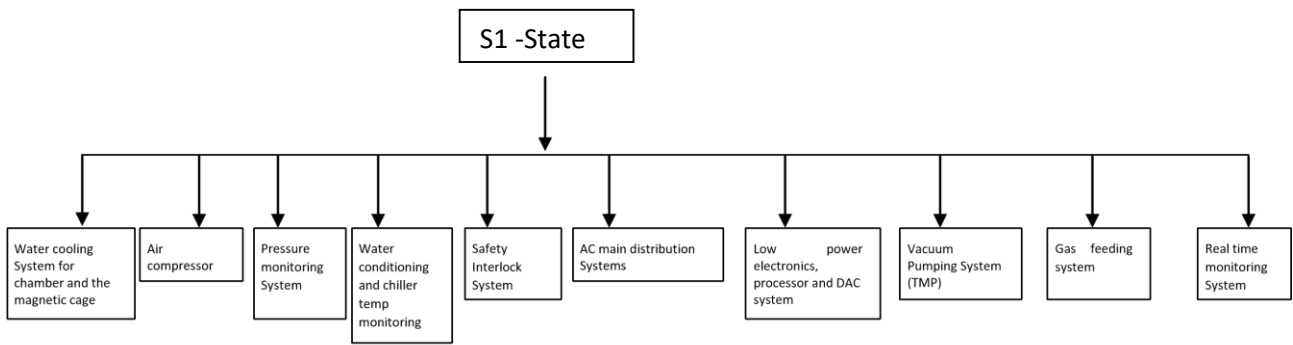

S1-S0 interlock: Slow

S2-S1 interlock: Slow

S3-S2 interlock: Slow

S4-S3 interlock: Fast

S4-S2 interlock: Fast

2.3 Interlocks

Interlocks are hard wired system and acts within 1 micro second. If the operating parameter crosses the maximum level specified by system designer, negative

Hydrogen ion beam and associated power supply will be withdrawn. In order to maintain operation, all these signals are connected to fault handling system.

- Dust Dropping Unit Heater exceeds the optimum value- Cut off (S3) state.
- If the set parameter of Filament, Discharge voltages falls below or rose above by accident S3-S1 Interlock will active.
- If arcing sensed in the floating chamber and any other fault blocks the negative ion beam within 10 μ s. After pre-defined recovery time t_{off} , the beam current is resumed with programmed parameter.
- If there is any trip in the HVPS for extraction and acceleration grids, cut off. Initiate S4-S3 interlock.
- If any sub-system fails or parameters are out of set value, system will straight away go to OFF State (S0) from higher state.

diagram and related interlock is shown in Figure.

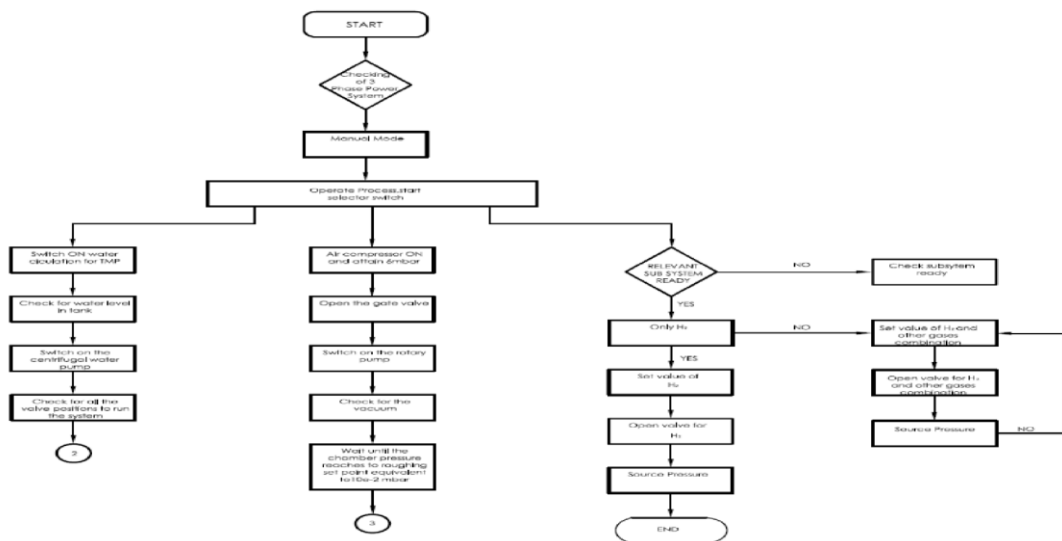
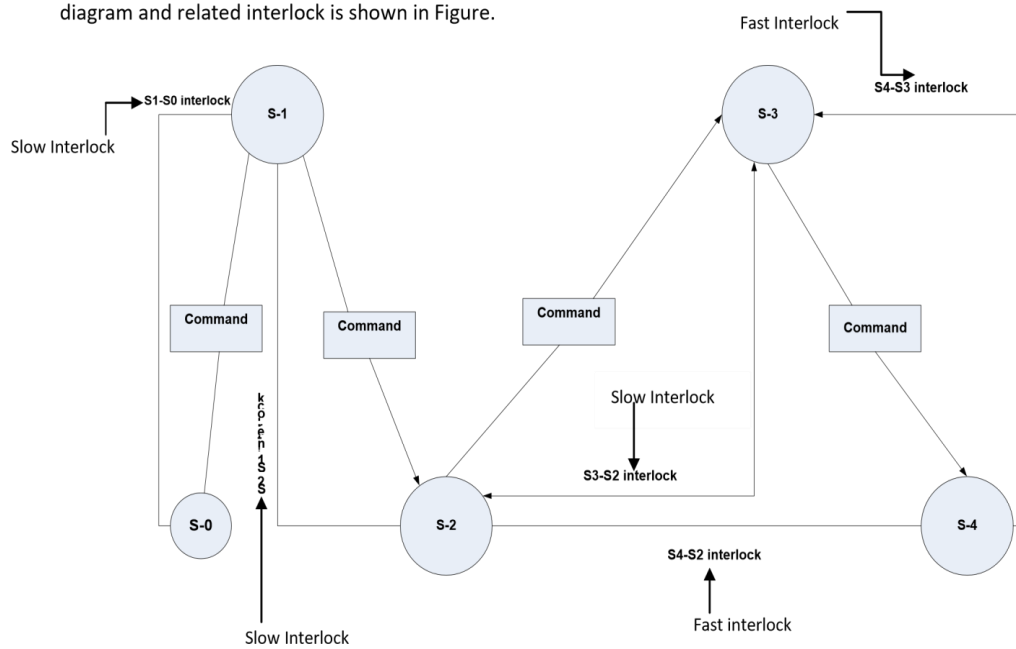

- While testing the Test Mock-Ups, if some arcing happens or temperature rises above the estimated value, system will go to S3-S2 state. The System will initiate this interlock.

- If the set parameter/any fault occurs in the S4 state and to control the dust dropping rate in the S3 state, system will immediately go to the states S4-S3 and S4-S2. It means S4-S3 and S4-S2 interlocks will initiate

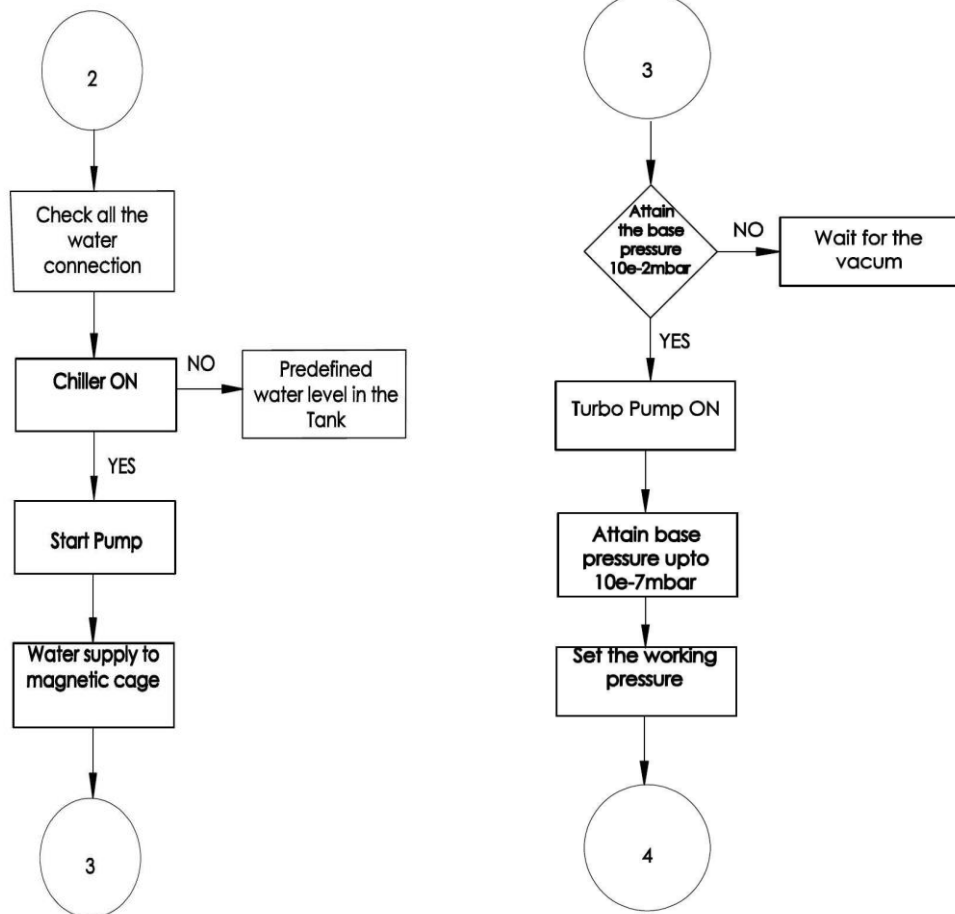

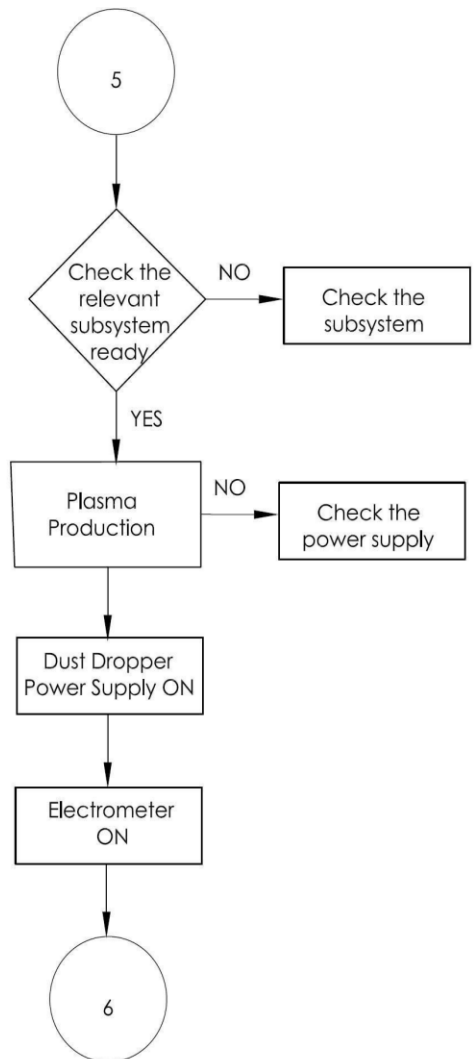
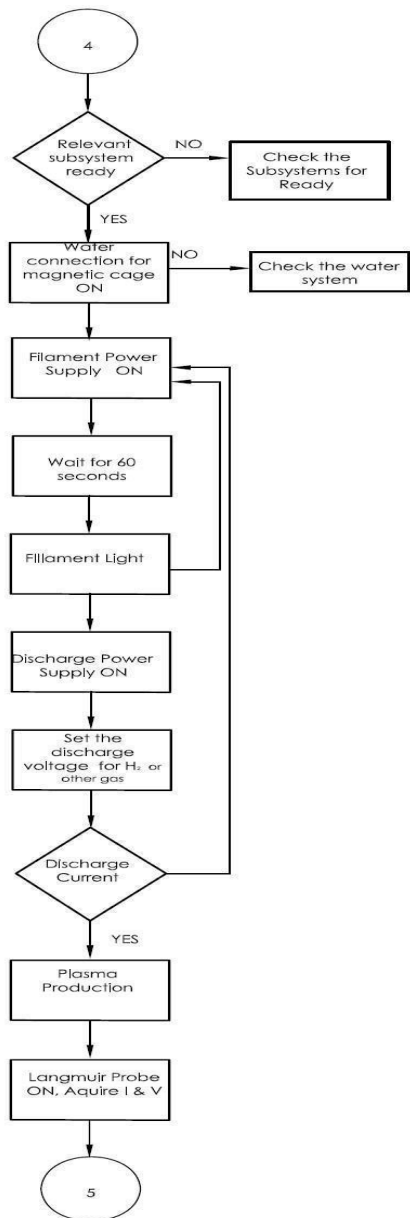

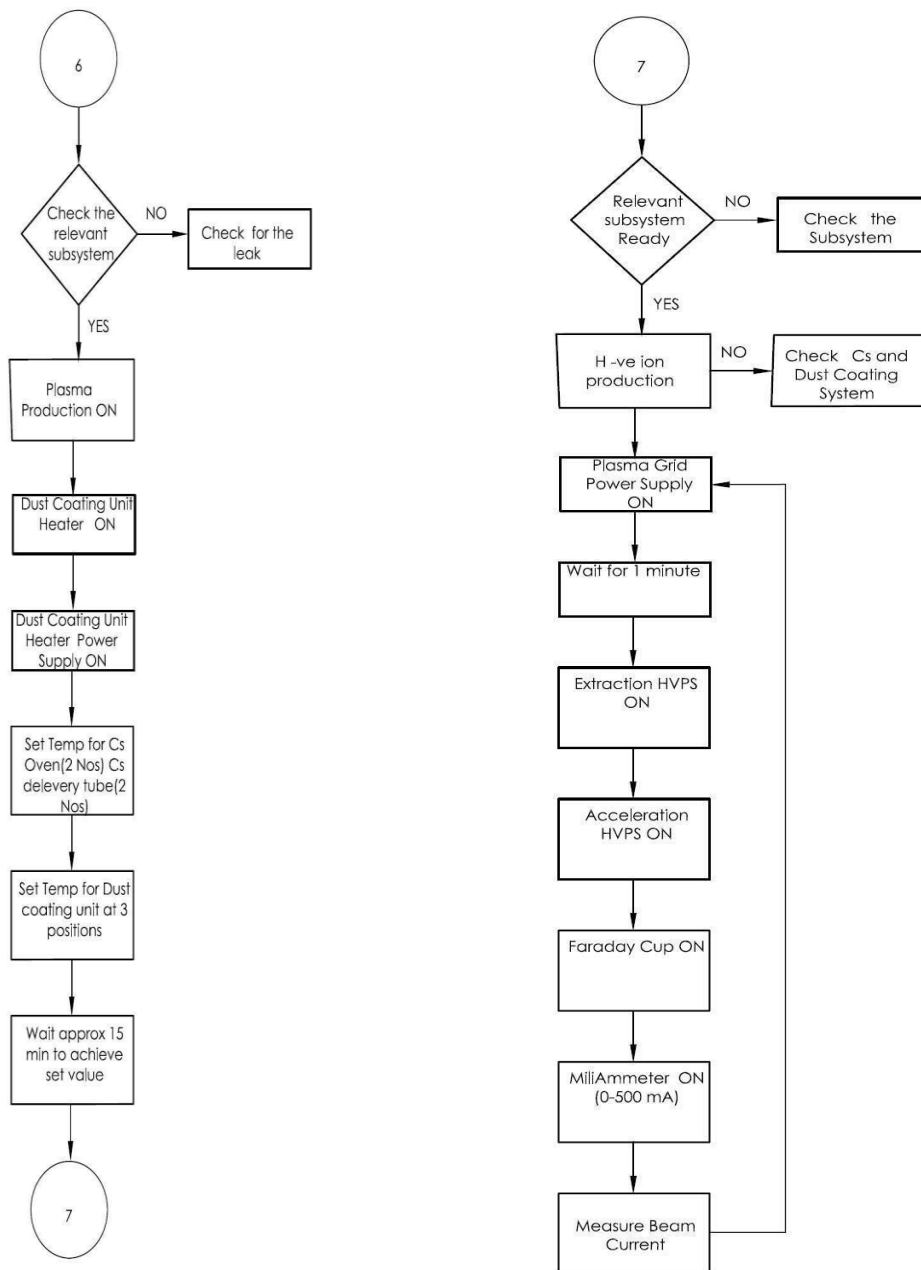

The following individual flowcharts are made for the experiments with and without cesium. This will refer to the masking and feedback control loops during the main experiments.

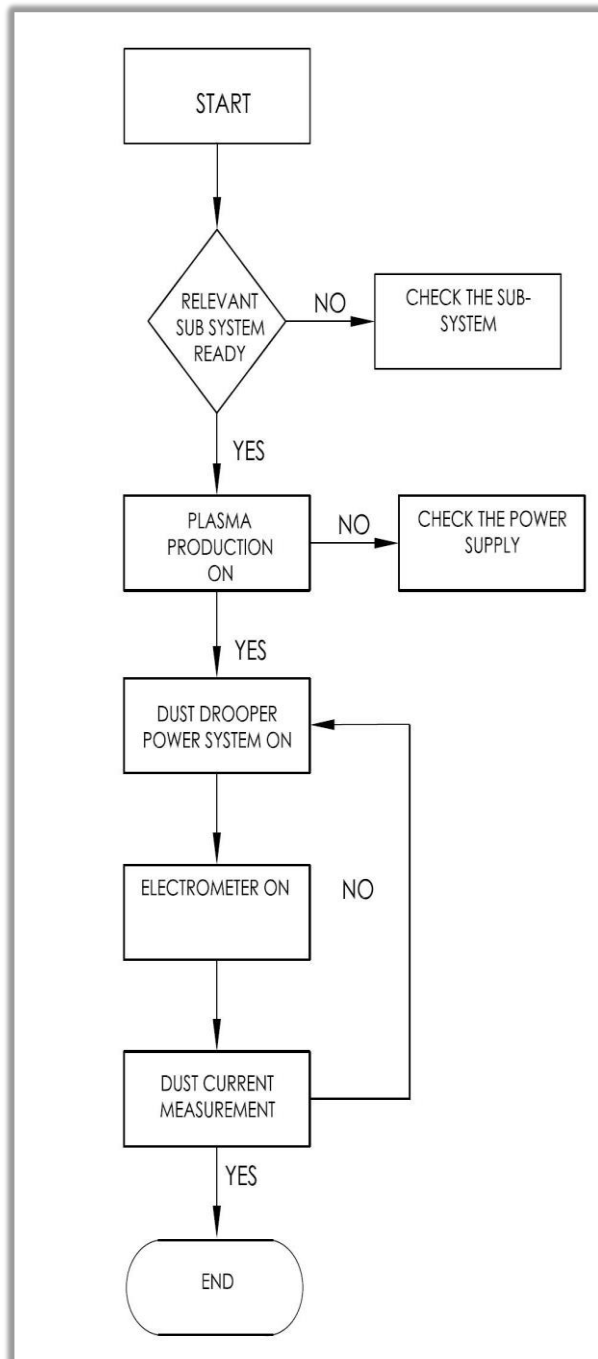
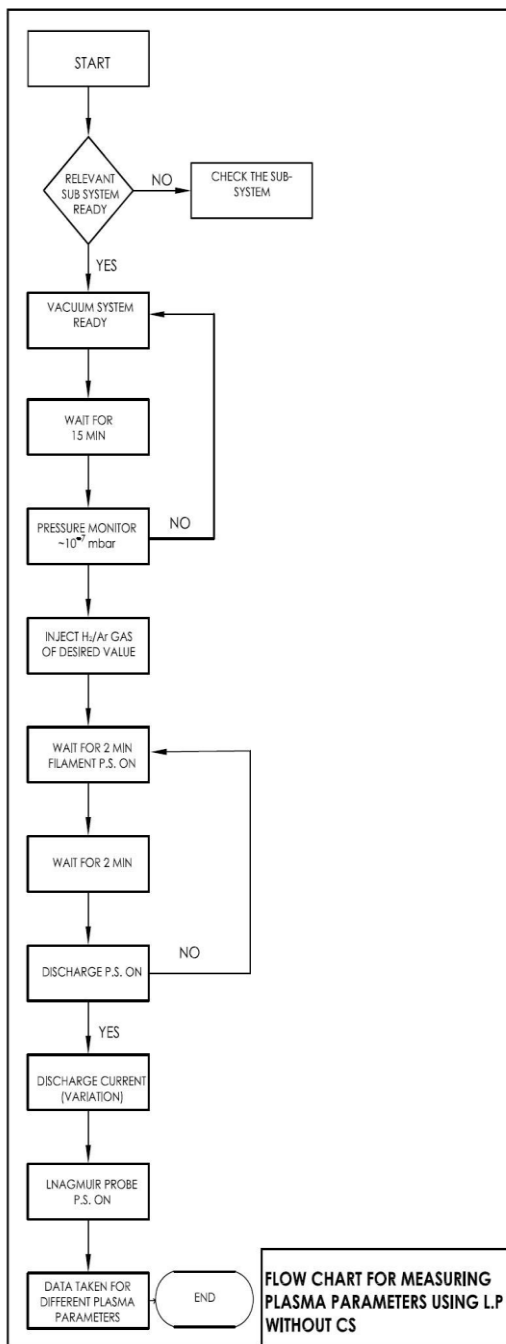

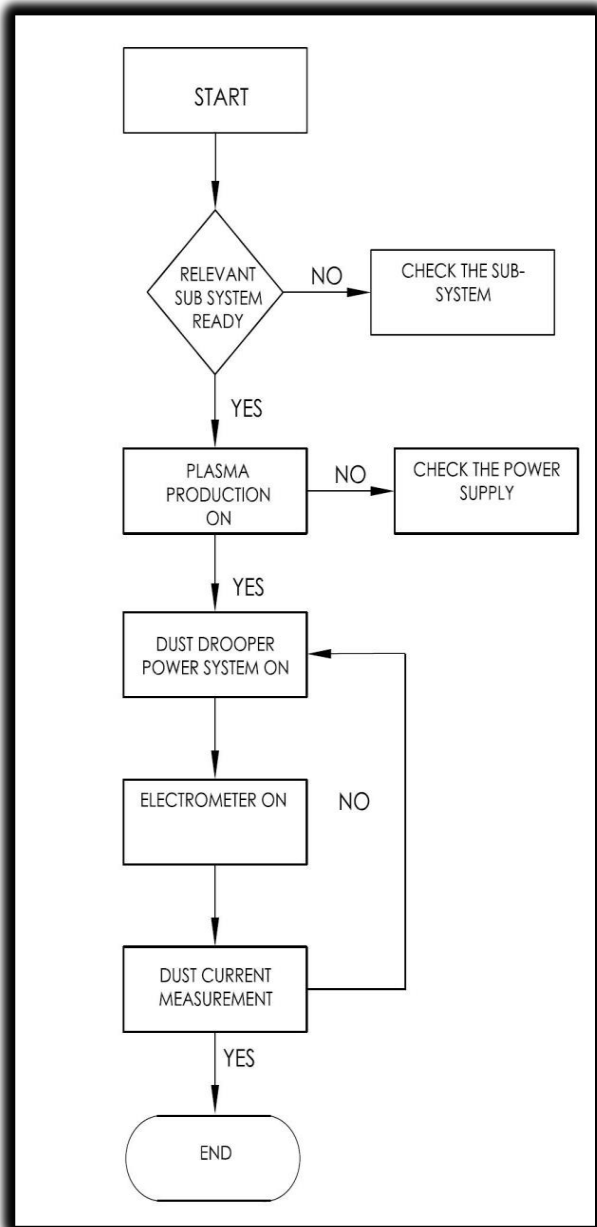

FLOW CHART FOR MEASURING PLASMA PARAMETERS USING LP WITHOUT CS

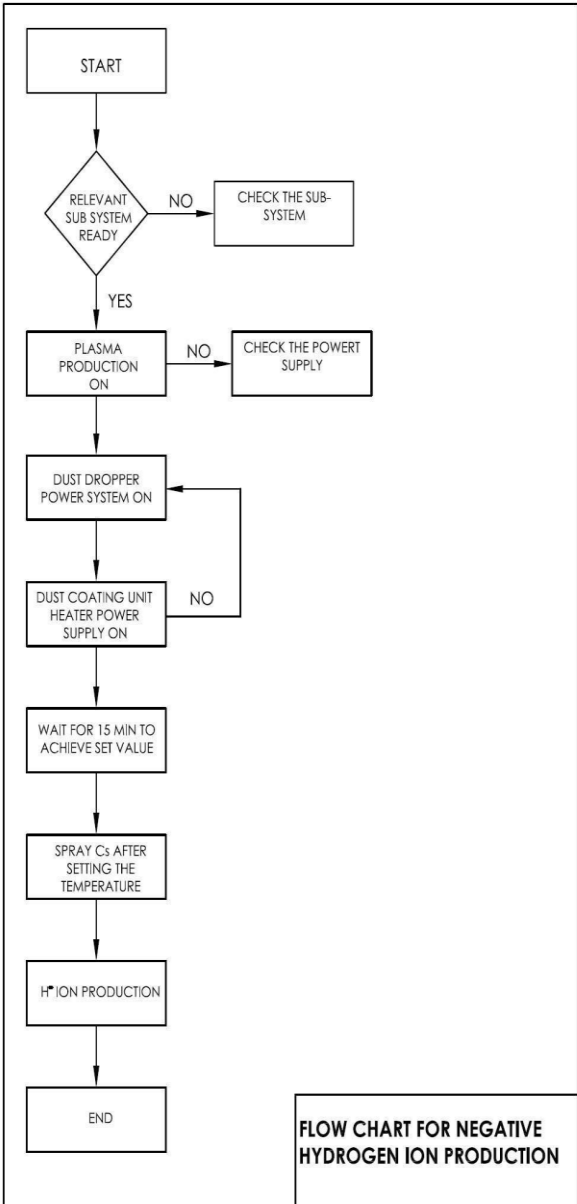

FLOW CHART FOR NEGATIVE HYDROGEN ION PRODUCTION

Timing Diagram of Negative Hydrogen Ion Extraction System

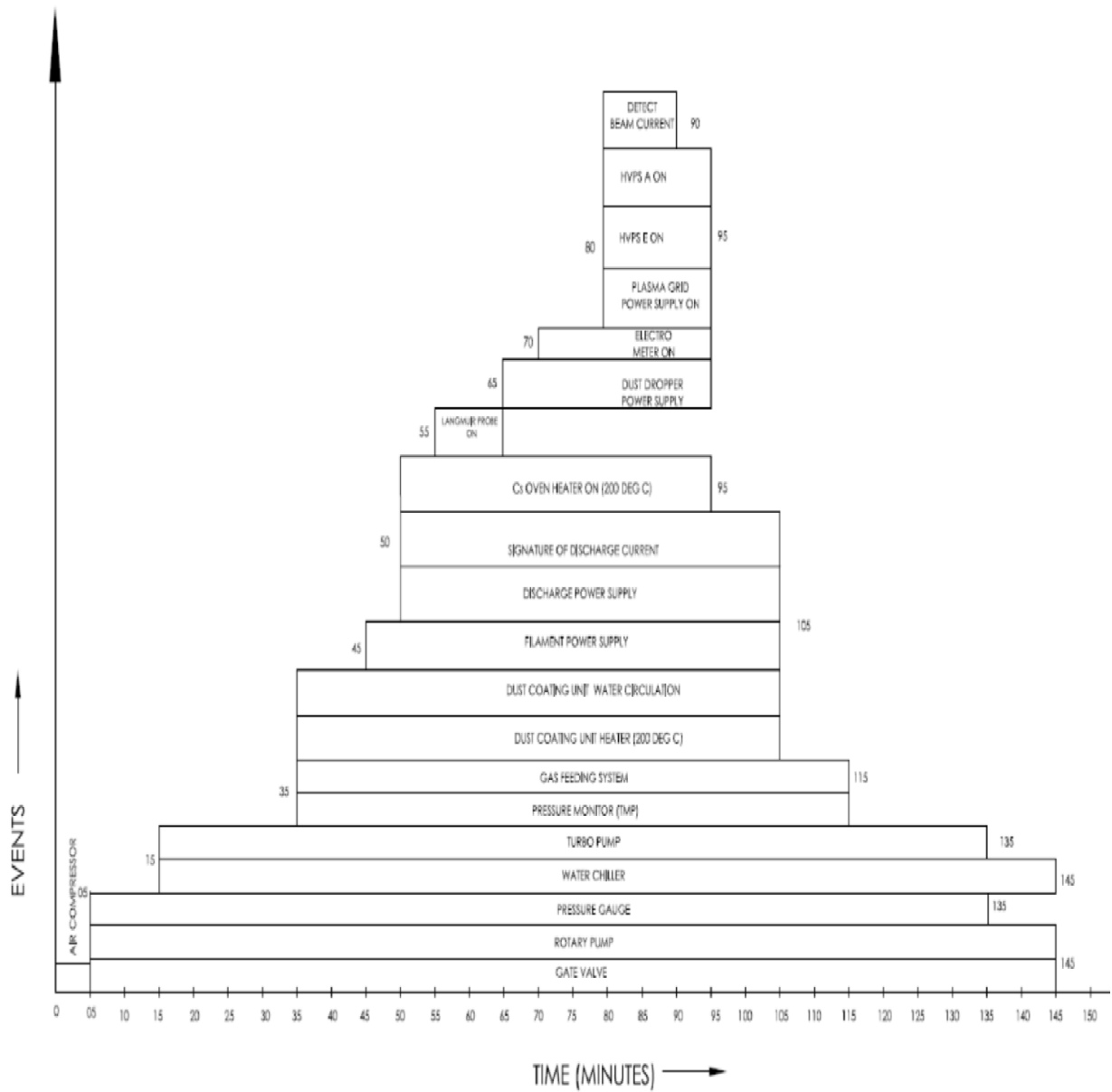

TIME DIAGRAM OF NHIE LAB

SIGNAL LIST for DACS & FO Links

Sr. No.	Item/Signal	F/G	DI	DO	AI	AO	Control	Monitor	Acquisition	Sampling Frequency	Scaling
1	Air compressor (ON/ OFF, TRIP, STAUS) (G)	G	2	1	0	0	1.ON/OFF	1.TRIP, 2.Status	NO	NO	
2	Gate valve (ON/ OFF, Status)(G)	G	1	1	0	0	1.ON/OFF	1.Status	NO	NO	
3	Rotary pump (ON/ OFF, Trip, Status)	G	2	1	0	0	1.ON/OFF	1.Trip 2.Status	NO	NO	
4	Pressure gauge (ON/ OFF, Status, Pressure Monitor)	G	1	1	1	0	1.ON/OFF	1. Status 2.Pressure Monitor	NO	1Hz	0- 10 V=760 Torr-10 ⁻⁹ Torr
5	Water circulation (ON/ OFF, Status, Flow rate) to TMP	G	1	1	1	0	1.ON/OFF	1.Status 2.Flow rate	NO	1Hz	
6	TMP (TMP Cooling _Ok, TMP_ERROR,TRIP, RUN_FEEDBACK, DRIVE_RESET,DRIVE START/STOP,STAND BY,VENT,TMP_SPEED,SPEED_SET)	G	4	4	1	1	1.Drive_Reset2.Drive Start/Stop, 3.Stand By, 4.Vent, 5.Speed_Set	1.TMP_speed, 2.TMP_error, 3.Run_Feedback, 4.TMPCooling_OK 5.Trip	1.TMP_SPEED	1kHz	
7	DFC -2 Nos(ON/OFF, Status, Flow control, Flow monitor)	G	2	2	2	2	1.ON/OFF 2.Flowcontrol	1.Status 2.Flowmonitor	1.Flow rate	1KHz	0- 10 V =0-100 sccm

8	Filament PS-2 Nos (ON/OFF, Local/Remote, Alarm, CV status, CC status, Vset, Iset, Vmonitor, Imonitor, Power On/Off status)	F	8	4	4	4	1.ON/OFF 2.V_Set 3.I_Set 4.Local/Remote	1.V_Monitor 2.I_Monitor 3.Power On/Off status 4.CC_Status 5.CV_Status 6.Alarm	1.V_Monitor 2.I_monitor 3.Power On/Off status	10KHz	0- 10 V= 0-32 V 0- 10 V =0-100 A
9	Discharge PS (ON/OFF, Local /Remote, Alarm, CVstatus, CCstatus, Vset, Iset, Vmonitor, Imonitor, Power On/Off status)	F	4	2	2	2	1.ON/OFF 2.V_Set 3.I_Set 4.Local/Remote	1.V_Monitor 2.I_Monitor 3.Power On/Off status 4.CC_Status 5.CV_Status 6.Alarm	1.V_Monitor 2.I_monitor 3.Power On/Off status	10KHz	0- 10 V =0-128 V 0- 10 V =28 A
10	Langmuir probe (ON/ OFF, Status, V set, IV monitor)	F	1	1	1	1	1.ON/OFF 2.V set	1.IV characteristics 2.Status	1.IV characteristics	Through RS485	
11	Dust coating unit heater – 3 nos (ON/ OFF, Status, control, Temperature Monitor)	G	3	3	3	3	1.ON/OFF 2.Control	1.Status 2.Temperature Monitor	NO	1Hz	0-10V = 0-300 °C
12	Dust coating unit water circulation (ON/OFF, Status)	G	1	1	0	0	1.ON/OFF	1.Status	NO	NO	
12a	Water regulation valve(Speed Control, flow rate)	G	0	0	1	1	1.Speed Control	1.Flow rate	NO	1Hz	

13	Cesium oven heater-2 nos (ON/ OFF, Status, Temp control, Temperature Monitor)	G	2	2	2	2	1.ON/OFF 2.Temp Control	1.Status 2.Temperature Monitor	NO	1 KHz	0-10V = 0-300 °C
14	Dust dropper PS (ON/OFF, Local/ Remote,Alarm,CVstatus,C Cstatus,,Vset, Iset, Vmonitor, Imonitor, Power On/Off status)	G	4	2	2	2	1.ON/OFF 2.V_Set 3.I_Set 4.Local/Remote	1.V_Monitor 2.I_Monitor 3.Power On/Off status 4.CC_Status 5.CV_Status 6.Alarm	1.V_Monitor 2.I_monitor 3.Power On/Off status	10KHz	0- 10 V=0-40 V 0- 10 V=0-20 A
15	Electrometer (ON/ OFF, Status, Value)	F	1	1	1	0	1.ON/OFF	1.Status 2. Current	1. Current	Through RS232	
16	HVPS E Remote Programming of voltage, Remote Programming of current, Remote Monitoring of voltage, Remote monitoring of current, Remote HV ON/OFF, STATUS signal for power supply trip, Arc Detection pulse, Arc Frequency, Arc Counter and Power supply trip	G	2	1	4	2	1.Remote programming of voltage. 2.Remote programming of current 3.Remote HV ON/OFF	1.STATUS signal for power supply trip. 2.Arc Detection Pulse 3. Arc Frequency 4.Arc Counter and Power supply trip 5.Remote monitoring of voltage 6.Remote monitoring of current	1.Voltage 2.Current	100KHz	0- 10 V=0-15 kV 0- 10 V=0-2 A

17	HVPS A Remote Programming of voltage, Remote Programming of current, Remote Monitoring of voltage, Remote monitoring of current, Remote HV ON/OFF, STATUS signal for power supply trip, Arc Detection pulse, Arc Frequency, Arc Counter and Power supply trip	G	2	1	4	2	1.Remote programming of voltage. 2.Remote programming of current 3.Remote HV ON/OFF	1.STATUS signal for power supply trip. 2.Arc Detection Pulse 3. Arc Frequency 4.Arc Counter and Power supply trip 5.Remote monitoring of voltage 6.Remote monitoring of current	1.Voltage 2.Current	100KHz	0- 10 V=0-15 kV 0- 10 V=0- 2 A
18	Faraday Cup & milli ammeter (ON/ OFF, Status, Current monitor)	G	1	1	1	0	1.ON/OFF	1.Status 2.Current	1.Current	1KHz	0-10V=0-500 mA
19	Water connection for magnetic cage (ON/OFF, Status)	F	1	1	0	0	1.ON/OFF	1.Status	NO	NO	
19a	Valve for Water connection for magnetic cage(Speed control , Flow rate)	F	0	0	1	1	1. Speed Control	1.Flow rate	NO	1 Hz	
20	Optical Emission Spectrometer (ON/OFF, Status, Spectrum)	G	1	1	1	0	1.ON/OFF	1.Status 2.Spectrum	1.Spectrum	Through Rs 232	
21	Plasma Grid Power Supply(ON/OFF, Local	F	4	2	2	2	1.ON/OFF 2.V_Set	1.V_Monitor 2.I_Monitor	1.V_Monitor 2.I_monitor	10KHz	

	/Remote, ,Alarm,CVstatus,CCstatus,, Vset, Iset, Vmonitor, Imonitor, Power On/Off status)						3.I_Set 4.Local/Remote	3.Power On/Off status 4.CC_Status 5.CV_Status 6.Alarm	3.Power On/Off status		0- 10 V=0- 40 V 10 V=0-20 A
22	Water level and temperature monitoring in the chiller	G	0	0	2	0		1.Water level 2.Temperature		1 Hz	
	Total I/Os		48	34	36	25					

TOTAL No. of Signals (DI+DO+AI+AO)=143 (Including 51 Floating Signals)

Note:

F/G stands for **Floating Signals** or **Grounded Signals**

DI stands for Digital Input

DO stands for Digital Output

AI stands for Analog Input

AO stands for Analog Output